



The new degree of comfort.®

## Rheem Classic Plus® Series Ducted Split Air Conditioners

### SAGN- Series Condensing Unit

Nominal Sizes 1.5 - 5.5 Ton [5.57 to 18.26 kW]



### EL3T- Series Low Height Air Handler

Constant Torque Motor (ECM)



**50Hz**



INTEGRATED AIR & WATER

## TABLE OF CONTENTS

Nomenclature .....	3
Available Models SKUs - Condensing Unit / Air Handler.....	4
Engineering Features SAGN Standard Features / EL3T Standard Features.....	5
Performance Data Calculation Procedure .....	6-10
Summary of Performance Data .....	11
Gross System Performance Data .....	12-19
Airflow Performance Data.....	20-21
Sound Pressure Valves.....	22
Electrical Data and Electrical Wiring.....	23
Units Dimensions.....	24-25
Airflow Directional Data.....	26
Refrigerant Line Application Guide .....	27-35
Wiring Diagram.....	36-39
Guides Specification.....	40-41

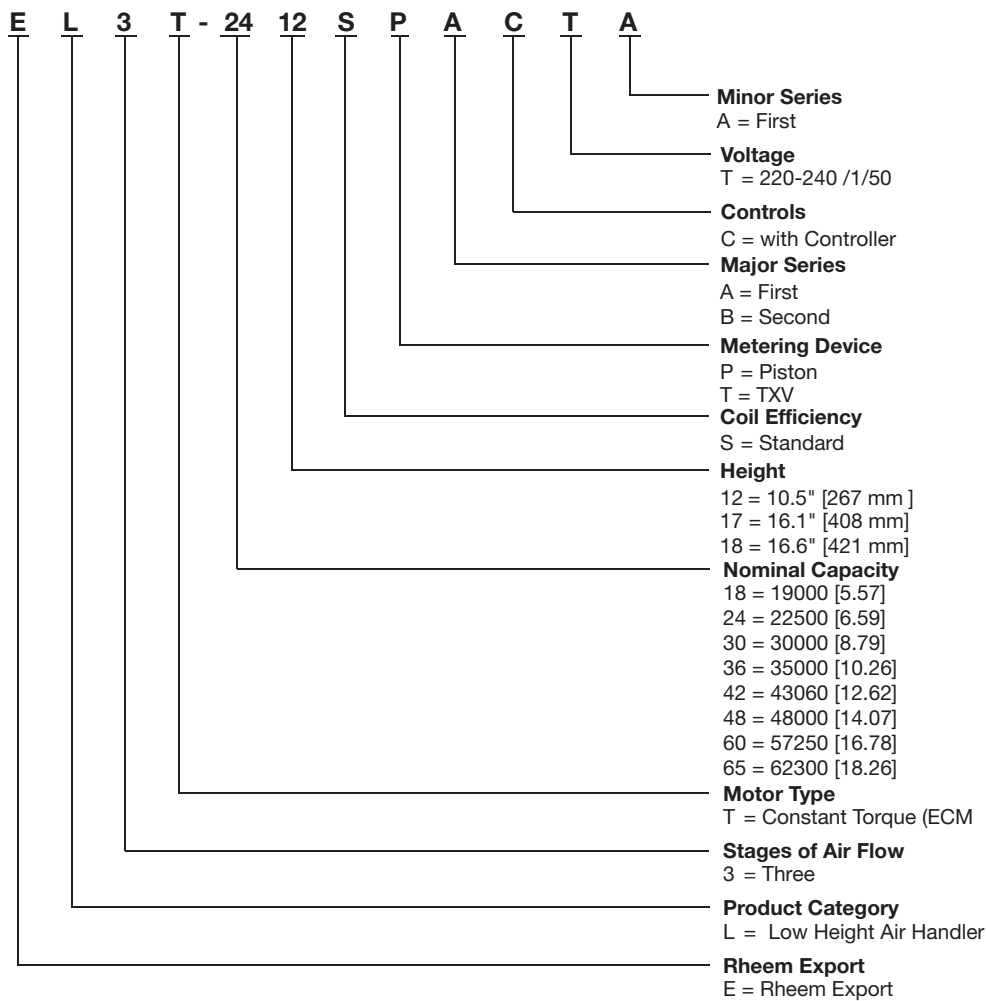
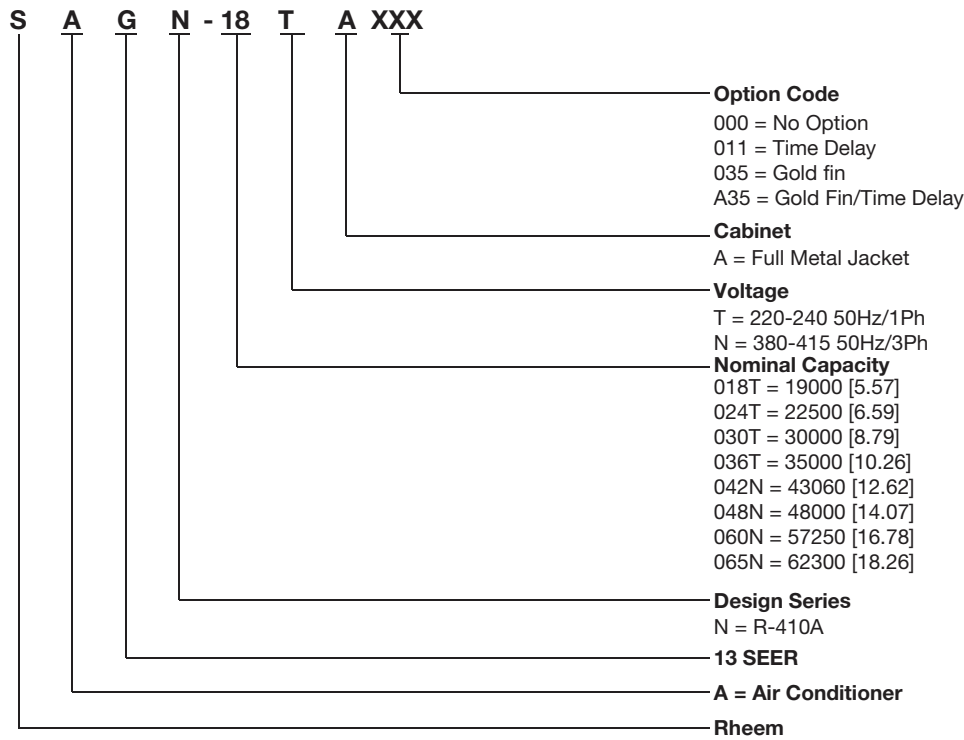

[ ] Designates Metric Conversions



## Available SKUs - Condensing Unit

Available Models	Description	Power Supply	
SAGN-018TA011	1-1/2 Ton Air Conditioner w/ Time Delay	220-240/1Ph/50Hz	
SAGN-018TA035	1-1/2 Ton Air Conditioner w/ Gold Fin		
SAGN-018TAA35	1-1/2 Ton Air Conditioner w/ Gold Fin/Time Delay		
SAGN-024TA011	2 Ton Air Conditioner w/ Time Delay		
SAGN-024TA035	2 Ton Air Conditioner w/ Gold Fin		
SAGN-024TAA35	2 Ton Air Conditioner w/ Gold Fin/Time Delay		
SAGN-030TA011	2-1/2 Ton Air Conditioner w/ Time Delay		
SAGN-030TA035	2-1/2 Ton Air Conditioner w/ Gold Fin		
SAGN-030TAA35	2-1/2 Ton Air Conditioner w/ Gold Fin/Time Delay		
SAGN-036TA011	3 Ton Air Conditioner w/ Time Delay		
SAGN-036TA035	3 Ton Air Conditioner w/ Gold Fin		
SAGN-036TAA35	3 Ton Air Conditioner w/ Gold Fin/Time Delay		
SAGN-042NA011	3-1/2 Ton Air Conditioner w/ Time Delay		380-415/3Ph/50Hz
SAGN-042NA035	3-1/2 Ton Air Conditioner w/ Gold Fin		
SAGN-042NAA35	3-1/2 Ton Air Conditioner w/ Gold Fin/Time Delay		
SAGN-048NA011	4 Ton Air Conditioner w/ Time Delay		
SAGN-048NA035	4 Ton Air Conditioner w/ Gold Fin		
SAGN-048NAA35	4 Ton Air Conditioner w/ Gold Fin/Time Delay		
SAGN-060NA011	5 Ton Air Conditioner w/ Time Delay		
SAGN-060NA035	5 Ton Air Conditioner w/ Gold Fin		
SAGN-060NAA35	5 Ton Air Conditioner w/ Gold Fin/Time Delay		
SAGN-065NA011	5-1/2 Ton Air Conditioner w/ Time Delay		
SAGN-065NA035	5-1/2 Ton Air Conditioner w/ Gold Fin		
SAGN-065NAA35	5-1/2 Ton Air Conditioner w/ Gold Fin/Time Delay		

## Available SKUs - Air Handler

Available Models	Description	Power Supply
EL3T1812SPBCTA	Low Height Air Handler w/ Constant Torque ECM Motor (Piston)	220-240/1Ph/50Hz
EL3T2412SPBCTA		
EL3T3012SPBCTA		
EL3T3612SPBCTA		
EL3T4217STACTA	Low Height Air Handler w/ Constant Torque ECM Motor (TXV)	
EL3T4817STACTA		
EL3T6017STACTA		
EL3T6518STACTA		
EL3T6518STACTA		



## SAGN STANDARD FEATURES

- Outdoor air conditioner designed for ground level or rooftop installations. These units offer comfort and dependability for single, multi-family and light commercial applications.
- Condenser coils constructed with copper tubing and enhanced aluminum fins.
- Grille/Motor mount for quiet fan operation
- Filter Drier (shipped – not installed)
- Scroll compressor is hermetically sealed and incorporates internal high temperature motor overload protection and durable insulation on the motor windings. It is internally spring mounted and externally mounted on rubber grommets to reduce vibration and noise.
- Compressors have an internal pressure-relief assembly to protect against excessive pressure differential.
- All refrigerant connections are on the exterior of the units, located close to the ground for neat appearing installations.
- Cabinet is constructed of painted galvanized steel rated at 1008 hours salt spray per ASTM-B117. The full wraparound louvered grille protects the coil from damage.
- The control box is located on the top side corner of the cabinet providing for easy access through a service panel.
- Service valves are standard on all models.
- Power and control wiring are kept separate.
- Every unit is factory charged and tested.
- Drawn base pan for extra corrosion resistance and sound reduction.

## Accessories

- Crankcase Heater
- Sound Enclosure

## EL3T STANDARD FEATURES

- All standard air handler models only 10.5" high. (up to 3TR only).
- Attractive pre-painted cabinet exterior.
- Rugged wall steel cabinet construction, designed for added strength and versatility.
- Insulation in blower compartment for excellent thermal and sound performance
- Resilient ring blower mount.
- Removable blower deck assembly for service and maintenance convenience.
- Indoor coil design provides low air side pressure drop, high performance and extremely compact size.
- Coils are constructed of aluminum fins bonded to internally grooved copper tubing.
- Coils are tested at the factory with an extensive refrigerant leak check.
- Coils have copper sweat refrigerant connections.
- Molded polymer corrosion resistant condensate drain pan is provided on all indoor coils.
- Connection point for both high and low voltage field wiring are located in the external control box on the side of the air handler cabinet.
- Refrigerant connections are located above external control box on the side of the unit. Drain connections are located on each side of the plastic drain pan.
- EL3T feature a Constant Torque motor (ECM) which provides enhanced EER performance with Rheem outdoor units.
- Factory-installed indoor coil.
- 1 1/2 ton [5.3 kW] through 3 ton [10.5 kW] models are 10.5 inches [267 mm] tall and between 24 3/8to 25 1/4inches [619 to 642 mm] deep.
- All models meet or exceed 300 to 400 CFM [156 to 189 L/s] per ton at .3 inches [.7 kPa] of external static pressure.
- Airflow up to .3" external static pressure (ESP) for 1.5 to 2.5 tons, up to .5" ESP for 3 ton and up to 0.8" ESP for models above 3 ton.

[ ] Designates Metric Conversions

## Performance Data Calculation Procedure

Apply interpolation method to get the required temperatures that are not stated in the table. Extrapolation is not allowed.

See the example of calculation procedure below:

### GROSS SYSTEMS PERFORMANCE DATA - SAGN-018TA+EL3T1812SPACTA

Indoor			Outdoor Temperature											
Air Flow CFM [L/s]	WBE	DBE	95°F [35°C]			115°F [46°C]			118.4°F [48°C]			126°F [52°C]		
			Total Capacity	Sensible Capacity	Power Input	Total Capacity	Sensible Capacity	Power Input	Total Capacity	Sensible Capacity	Power Input	Total Capacity	Sensible Capacity	Power Input
			MBH	MBH	kW	MBH	MBH	kW	MBH	MBH	kW	MBH	MBH	kW
430 [203]	61°F [16°C]	70°F	17.06	11.51	1.49	15.20	10.51	1.87	14.82	10.34	1.94	13.94	9.93	2.11
		75°F	16.85	13.70	1.48	15.05	12.87	1.87	14.84	12.56	1.94	14.01	12.22	2.12
		81°F	17.26	16.59	1.48	15.31	15.20	1.87	14.99	14.92	1.93	14.35	14.34	2.09
		86°F	17.70	17.70	1.50	16.12	16.12	1.88	15.81	15.81	1.95	15.34	15.34	2.08
	66°F [19°C]	75°F	18.53	11.44	1.50	16.55	10.49	1.88	16.31	10.54	1.96	15.37	10.06	2.12
		81°F	18.66	14.43	1.50	16.59	13.25	1.89	16.30	13.27	1.96	15.32	12.58	2.13
		86°F	18.76	16.46	1.51	16.75	15.87	1.89	16.38	15.68	1.96	15.84	15.42	2.08
		91°F	18.96	18.96	1.50	17.27	17.27	1.89	16.79	16.79	1.96	16.32	16.32	2.09
	72°F [22°C]	81°F	20.98	11.51	1.53	18.57	10.58	1.92	18.22	10.44	1.97	17.12	10.02	2.15
		86°F	20.92	13.89	1.53	18.53	12.91	1.92	18.25	12.85	1.97	17.14	12.41	2.15
		91°F	20.77	16.02	1.52	18.40	15.06	1.90	18.20	14.97	1.97	17.11	14.56	2.15
		97°F	20.78	18.87	1.52	18.73	18.20	1.91	18.35	18.05	1.97	17.69	17.69	2.07

Required conditions:

Outdoor temperature: 120°F  
 On-coil temperature [DB/WB]: 76°F/63°F  
 Airflow: 430 CFM

From the Performance table, the following are determined:

- 76°F DB is between 75°F and 81°F, interpolation can be applied
- 63°F WB is between 61°F and 66°F, interpolation can be applied
- 120°F outdoor temperature is between 118.4°F and 126°F, interpolation can be applied

Indoor			Outdoor Temperature											
Air Flow CFM [L/s]	WBE	DBE	95°F [35°C]			115°F [46°C]			<b>118.4°F [48°C]</b>			<b>126°F [52°C]</b>		
			Total Capacity	Sensible Capacity	Power Input	Total Capacity	Sensible Capacity	Power Input	Total Capacity	Sensible Capacity	Power Input	Total Capacity	Sensible Capacity	Power Input
			MBH	MBH	kW	MBH	MBH	kW	MBH	MBH	kW	MBH	MBH	kW
430 [203]	<b>61°F [16°C]</b>	70°F	17.06	11.51	1.49	15.20	10.51	1.87	14.82	10.34	1.94	13.94	9.93	2.11
		75°F	16.85	13.70	1.48	15.05	12.87	1.87	14.84	12.56	1.94	14.01	12.22	2.12
		<b>76°F</b>							<b>Step 1</b>			<b>Step 3</b>		
		81°F	17.26	16.59	1.48	15.31	15.20	1.87	14.99	14.92	1.93	14.35	14.34	2.09
	<b>66°F [19°C]</b>	86°F	17.70	17.70	1.50	16.12	16.12	1.88	15.81	15.81	1.95	15.34	15.34	2.08
		75°F	18.53	11.44	1.50	16.55	10.49	1.88	16.31	10.54	1.96	15.37	10.06	2.12
		<b>76°F</b>							<b>Step 2</b>			<b>Step 4</b>		
		81°F	18.66	14.43	1.50	16.59	13.25	1.89	16.30	13.27	1.96	15.32	12.58	2.13
	<b>72°F [22°C]</b>	86°F	18.76	16.46	1.51	16.75	15.87	1.89	16.38	15.68	1.96	15.84	15.42	2.08
		91°F	18.96	18.96	1.50	17.27	17.27	1.89	16.79	16.79	1.96	16.32	16.32	2.09
		81°F	20.98	11.51	1.53	18.57	10.58	1.92	18.22	10.44	1.97	17.12	10.02	2.15
		86°F	20.92	13.89	1.53	18.53	12.91	1.92	18.25	12.85	1.97	17.14	12.41	2.15
<b>72°F [22°C]</b>	91°F	20.77	16.02	1.52	18.40	15.06	1.90	18.20	14.97	1.97	17.11	14.56	2.15	
	97°F	20.78	18.87	1.52	18.73	18.20	1.91	18.35	18.05	1.97	17.69	17.69	2.07	

Solution:

Step 1: Interpolate to get the values of TC, SC and PI at 76°F/61°F On coil and outdoor 118.4°F.

Air Flow CFM [L/s]	WBE	DBE	118.4°F [48°C]		
			Total Capacity	Sensible Capacity	Power Input
			MBH	MBH	kW
430 [203]	61°F [16°C]	70°F	14.82	10.34	1.94
		75°F	14.84	12.56	1.94
		<b>76°F</b>	<b>Step 1</b>		
		81°F	14.99	14.92	1.93
		86°F	15.81	15.81	1.95

$$TC_1: \frac{76^\circ\text{F}-75^\circ\text{F}}{81^\circ\text{F}-75^\circ\text{F}} = \frac{TC_1-14.84}{14.99-14.84}$$

$$TC_1: 14.865 \text{ MBH}$$

Follow the same steps to get SC<sub>1</sub> and PI<sub>1</sub>.

$$SC_1: 12.953 \text{ MBH}$$

$$PI_1: 1.938 \text{ kW}$$

Step 2: Interpolate to get the values of TC, SC and PI at 76°F/66°F On coil and outdoor 118.4°F.

Air Flow CFM [L/s]	WBE	DBE	118.4°F [48°C]		
			Total Capacity	Sensible Capacity	Power Input
			MBH	MBH	kW
430 [203]	66°F [19°C]	75°F	16.31	10.54	1.96
		<b>76°F</b>	<b>Step 2</b>		
		81°F	16.30	13.27	1.96
		86°F	16.38	15.68	1.96
		91°F	16.79	16.79	1.96

$$TC_2: \frac{76^\circ\text{F}-75^\circ\text{F}}{81^\circ\text{F}-75^\circ\text{F}} = \frac{TC_2-16.31}{16.30-16.31}$$

$$TC_2: 16.308 \text{ MBH}$$

Follow the same steps to get SC<sub>2</sub> and PI<sub>2</sub>.

$$SC_2: 10.995 \text{ MBH}$$

$$PI_2: 1.96 \text{ kW}$$

Step 3: Interpolate to get the values of TC, SC and PI at 76°F/61°F On-coil and outdoor 126°F.

Air Flow CFM [L/s]	WBE	DBE	126°F [52°C]		
			Total Capacity MBH	Sensible Capacity MBH	Power Input kW
430 [203]	61°F [16°C]	70°F	13.94	9.93	2.11
		75°F	14.01	12.22	2.12
		<b>76°F</b>	<b>Step 3</b>		
		81°F	14.35	14.34	2.09
		86°F	15.34	15.34	2.08

$$TC_3: \frac{76^\circ\text{F}-75^\circ\text{F}}{81^\circ\text{F}-75^\circ\text{F}} = \frac{TC_3-14.01}{14.35-14.01}$$

$$TC_3: 14.067 \text{ MBH}$$

Follow the same steps to get SC<sub>3</sub> and PI<sub>3</sub>.

$$SC_3: 12.573 \text{ MBH}$$

$$PI_3: 2.115 \text{ kW}$$

Step 4: Interpolate to get the values of TC, SC and PI at 76°F/66°F On-coil and outdoor 126°F.

Air Flow CFM [L/s]	WBE	DBE	126°F [52°C]		
			Total Capacity MBH	Sensible Capacity MBH	Power Input kW
430 [203]	66°F [19°C]	75°F	15.37	10.06	2.12
		<b>76°F</b>	<b>Step 4</b>		
		81°F	15.32	12.58	2.13
		86°F	15.84	15.42	2.08
		91°F	16.32	16.32	2.09

$$TC_4: \frac{76^\circ\text{F}-75^\circ\text{F}}{81^\circ\text{F}-75^\circ\text{F}} = \frac{TC_4-15.37}{15.32-15.37}$$

$$TC_4: 15.361 \text{ MBH}$$

Follow the same steps to get SC<sub>4</sub> and PI<sub>4</sub>.

$$SC_4: 10.48 \text{ MBH}$$

$$PI_4: 2.12 \text{ kW}$$



Step 5: Interpolate the results of TC, SC and PI at 76°F/61°F in Step 1 [118.4°F] and Step 3 [126°F] to get the values at Step 5 [120°F].

Indoor			118.4°F [48°C]			120°F [48.9°C]			126°F [52°C]		
Air Flow CFM [L/s]	WBE	DBE	Total Capacity	Sensible Capacity	Power Input	Total Capacity	Sensible Capacity	Power Input	Total Capacity	Sensible Capacity	Power Input
			MBH	MBH	kW	MBH	MBH	kW	MBH	MBH	kW
430 [203]	61°F [16°C]	<b>76°F</b>	14.87	12.95	1.94	<b>Step 5</b>			14.07	12.57	2.12

TC<sub>5</sub>: 14.67 MBH  
 SC<sub>5</sub>: 12.86 MBH  
 PI<sub>5</sub>: 1.985 kW

Step 6: Interpolate the results of TC, SC and PI at 76°F/66°F in Step 2 [118.4°F] and Step 4 [126°F] to get the values at Step 6 [120°F].

Indoor			Outdoor Temperature								
			118.4°F [48°C]			120°F [48.9°C]			126°F [52°C]		
Air Flow CFM [L/s]	WBE	DBE	Total Capacity	Sensible Capacity	Power Input	Total Capacity	Sensible Capacity	Power Input	Total Capacity	Sensible Capacity	Power Input
			MBH	MBH	kW	MBH	MBH	kW	MBH	MBH	kW
430 [203]	66°F [19°C]	<b>76°F</b>	16.31	11.00	1.96	<b>Step 6</b>			15.36	10.48	2.12

TC<sub>6</sub>: 16.073 MBH  
 SC<sub>6</sub>: 10.87 MBH  
 PI<sub>6</sub>: 2.0 kW

Step 7: Interpolate the results of TC, SC and PI of Step 5 [76°F/61°F and 120°F] and Step 6 [76°F/66°F and 120°F] to get the values at 76°F/63°F On-coil and 120°F outdoor.

Indoor			Outdoor Temperature		
			120°F [48.9°C]		
Air Flow CFM [L/s]	WBE	DBE	Total Capacity	Sensible Capacity	Power Input
			MBH	MBH	kW
430 [203]	61°F [16°C]	76°F	14.67	12.86	1.99
	63°F [19°C]	<b>76°F</b>	<b>Step 7</b>		
	66°F [19°C]	76°F	16.07	10.87	2.00

TC<sub>7</sub>: 15.23 MBH  
 SC<sub>7</sub>: 12.06 MBH  
 PI<sub>7</sub>: 1.99 kW

## Combination T1/T3 Ratings - SAGN and EL3T

ODU SAGN	IDU EL3T	T1 Rated Capacity (BTUH)	T1 Rated EER	T1 Rated Power (kW)	T1 Rated Current (A)	T3 Rated Capacity (BTUH)	T3 Rated EER	T3 Rated Power (kW)	T3 Rated Current (A)	Gross Capacity @MEW**	Gross EER @MEW**	Outdoor Sound Power Rating dBA	Estimated Annual Energy Consumption (kW*Hr)
SAGN-018TA	EL3T1812SPBCTA	19000	13.00	1.461	7.42	17000	9.09	1.570	10.10	15699	9.81	62	3945*
SAGN-024TA	EL3T2412SPBCTA	22500	13.00	1.731	8.79	19600	9.72	1.710	12.40	18861	9.80	62	4674*
SAGN-030TA	EL3T3012SPBCTA	30000	13.00	2.308	11.70	26500	9.00	2.500	14.80	24335	9.91	60	6232*
SAGN-036TA	EL3T3612SPBCTA	35000	11.80	2.966	14.60	30500	9.40	3.230	18.00	29704	9.09	64	8008*
SAGN-042NA	EL3T4217STACTA	43061	13.05	3.300	4.81	40000	9.66	4.140	5.91	36360	8.12	75	8910*
SAGN-048NA	EL3T4817STACTA	45000	13.19	3.43	5.00	42335	10.08	4.20	6.00	43912	9.09	73	10665*
SAGN-060NA	EL3T6017STACTA	57250	11.80	4.850	7.30	53300	9.67	5.515	8.72	49821	8.24	75	13095*
SAGN-065NA	EL3T6518STACTA	62300	12.13	5.138	7.99	58500	9.36	6.250	9.43	53610	8.35	77	13872*

\*Estimated Annual Energy Consumption values are calculated based on T1 conditions and 2700hrs usage per year

\*\*MEW Condition: 80°F DB / 67°F WB Indoor Air, 118.4°F [48°C] DB Outdoor Air



**SUMMARY OF PERFORMANCE DATA**

SAGN-018TA+EL3T1812	Airflow	Total Capacity	Sensible Capacity	Power Input
	CFM	MBTUH	MBTUH	kW
115°F - 80°F/67°F	430	16.41	11.98	1.66
	525	16.56	12.42	1.68
	700	16.69	13.04	1.71
115°F - 76°F/63°F	430	15.21	11.97	1.65
	525	15.41	12.33	1.66
	700	15.58	12.83	1.69

SAGN-024TA+EL3T2412	Airflow	Total Capacity	Sensible Capacity	Power Input
	CFM	MBTUH	MBTUH	kW
115°F - 80°F/67°F	650	19.20	14.85	1.73
	700	19.41	15.46	1.75
	783	19.41	15.98	1.80
115°F - 76°F/63°F	650	17.91	14.57	1.73
	700	18.02	15.07	1.74
	783	18.11	15.72	1.78

SAGN-030TA+EL3T3012	Airflow	Total Capacity	Sensible Capacity	Power Input
	CFM	MBTUH	MBTUH	kW
115°F - 80°F/67°F	1021	25.21	18.29	2.51
	1077	25.57	19.16	2.56
	1175	26.14	21.29	2.65
115°F - 76°F/63°F	1021	23.28	18.09	2.51
	1077	23.63	18.94	2.54
	1175	24.31	20.90	2.64

SAGN-036TA+EL3T3612	Airflow	Total Capacity	Sensible Capacity	Power Input
	CFM	MBTUH	MBTUH	kW
115°F - 80°F/67°F	1021	30.05	22.41	3.44
	1077	30.16	22.87	3.48
	1175	30.57	24.08	3.52
115°F - 76°F/63°F	1021	27.72	22.07	3.43
	1077	27.78	22.48	3.47
	1175	28.19	23.55	3.52

SAGN-036NA+EL3T3612	Airflow	Total Capacity	Sensible Capacity	Power Input
	CFM	MBTUH	MBTUH	kW
115°F - 80°F/67°F	990	32.28	24.08	3.56
	1050	32.40	24.57	3.60
	1140	32.83	25.87	3.65
115°F - 76°F/63°F	990	29.78	23.71	3.55
	1050	29.84	24.14	3.59
	1140	30.28	25.30	3.64

SAGN-042NA+EL3T4217	Airflow	Total Capacity	Sensible Capacity	Power Input
	CFM	MBTUH	MBTUH	kW
115°F - 80°F/67°F	930	35.13	31.97	3.56
	1050	35.87	32.71	3.58
	1163	36.60	33.44	3.62
115°F - 76°F/63°F	930	32.62	29.46	3.52
	1050	33.38	30.22	3.60
	1163	33.97	30.81	3.62

SAGN-048NA+EL3T4817	Airflow	Total Capacity	Sensible Capacity	Power Input
	CFM	MBTUH	MBTUH	kW
115°F - 80°F/67°F	1300	41.20	37.58	3.53
	1450	41.61	37.99	3.57
	1609	41.97	38.35	3.64
115°F - 76°F/63°F	1300	38.40	34.78	3.52
	1450	39.03	35.41	3.56
	1609	39.06	35.44	3.60

SAGN-060NA+EL3T6017	Airflow	Total Capacity	Sensible Capacity	Power Input
	CFM	MBTUH	MBTUH	kW
115°F - 80°F/67°F	1750	50.46	42.50	5.51
	1873	49.27	44.08	5.69
	2015	49.55	45.80	5.78
115°F - 76°F/63°F	1750	44.52	40.93	5.50
	1873	44.51	42.09	5.63
	2015	44.99	43.50	5.73

SAGN-065NA+EL3T6518	Airflow	Total Capacity	Sensible Capacity	Power Input
	CFM	MBTUH	MBTUH	kW
115°F - 80°F/67°F	2203	55.01	49.43	5.61
	2250	53.32	50.14	5.70
	2322	53.45	51.02	5.71
115°F - 76°F/63°F	2203	48.38	46.70	5.62
	2250	48.95	48.57	5.69
	2322	55.15	48.87	5.68



**GROSS SYSTEMS PERFORMANCE DATA - SAGN-018TA+EL3T1812SPBCTA**

Indoor		Outdoor Ambient Temperature, DB																			
		95°F [35°C]				115°F [46°C]				118°F [48°C]				126°F [52°C]							
		Total Capacity kW	MBH	Sensible Capacity kW	Power Input kW	Total Capacity kW	MBH	Sensible Capacity kW	Power Input kW	Total Capacity kW	MBH	Sensible Capacity kW	Power Input kW	Total Capacity kW	MBH	Sensible Capacity kW	Power Input kW				
430 [203]	WBE DBE	70°F 21°C	4.86	16.58	3.28	11.18	3.00	10.22	1.65	4.22	14.41	2.94	10.05	1.70	3.97	13.55	2.83	9.65	1.85		
		75°F 24°C	4.80	16.38	3.90	13.32	3.67	12.51	1.64	4.23	14.42	3.68	12.21	1.71	3.99	13.62	3.48	11.87	1.86		
		81°F 27°C	4.92	16.78	4.73	16.12	4.33	14.88	1.65	4.27	14.57	4.25	14.50	1.70	4.09	13.95	4.08	13.94	1.83		
		86°F 30°C	5.04	17.21	5.04	17.21	4.59	15.66	1.65	4.50	15.37	4.50	15.37	1.71	4.37	14.91	4.37	14.91	1.82		
	WBE DBE	75°F 24°C	5.28	18.01	3.26	11.12	3.26	11.12	1.32	4.71	16.09	2.99	10.20	1.66	4.65	15.85	3.00	10.24	2.87	9.78	1.87
		81°F 27°C	5.32	18.14	4.11	14.03	3.77	12.88	1.66	4.64	15.84	3.78	12.90	1.72	4.36	14.89	3.58	12.23	1.87		
		86°F 30°C	5.34	18.24	4.69	16.00	4.52	15.42	1.67	4.67	15.93	4.47	15.24	1.72	4.51	15.40	4.39	14.99	1.83		
		91°F 33°C	5.40	18.43	5.40	18.43	4.92	16.79	1.66	4.78	16.32	4.78	16.32	1.72	4.65	15.87	4.65	15.87	1.84		
	WBE DBE	72°F 22°C	5.98	20.40	3.28	11.19	3.01	10.28	1.69	5.19	17.71	2.97	10.15	1.73	4.88	16.64	2.85	9.74	1.89		
		78°F 26°C	5.96	20.34	3.96	13.50	3.68	12.55	1.69	5.20	17.74	3.66	12.49	1.73	4.88	16.66	3.54	12.06	1.89		
		84°F 29°C	5.92	20.19	4.56	15.57	4.29	14.63	1.67	5.19	17.69	4.27	14.55	1.73	4.88	16.64	4.15	14.15	1.89		
		90°F 32°C	5.92	20.20	5.38	18.34	5.19	17.69	1.68	5.23	17.83	5.14	17.55	1.73	5.04	17.20	5.04	17.20	1.82		
52.5 [248]	WBE DBE	70°F 21°C	4.90	16.72	3.35	11.44	3.10	10.58	1.66	4.24	14.45	3.03	10.35	1.72	4.01	13.69	2.94	10.05	1.87		
		75°F 24°C	4.94	16.86	4.04	13.78	3.77	12.86	1.66	4.29	14.65	3.73	12.74	1.72	4.03	13.75	3.60	12.30	1.86		
		81°F 27°C	4.97	16.94	4.84	16.53	4.41	15.04	1.65	4.29	14.64	4.29	14.64	1.72	4.21	14.35	4.21	14.35	1.83		
		86°F 30°C	5.17	17.64	5.17	17.64	4.68	15.96	1.67	4.57	15.60	4.57	15.60	1.73	4.43	15.12	4.43	15.12	1.86		
700 [330]	WBE DBE	75°F 24°C	5.39	18.38	3.37	11.49	3.10	10.59	1.68	4.66	15.92	3.05	10.41	1.73	4.51	15.39	2.98	10.18	1.84		
		81°F 27°C	5.34	18.23	4.16	14.19	3.33	12.28	1.68	4.69	15.99	3.86	13.18	1.74	4.50	15.37	3.79	12.94	1.84		
		86°F 30°C	5.32	18.14	4.82	16.44	4.69	16.01	1.68	4.73	16.14	4.63	15.80	1.73	4.55	15.53	4.55	15.53	1.85		
		91°F 33°C	5.45	18.61	5.45	18.61	4.97	16.97	1.68	4.89	16.68	4.89	16.68	1.73	4.74	16.16	4.74	16.16	1.86		
72°F [22°C]	WBE DBE	70°F 21°C	6.09	20.79	3.39	11.57	3.08	10.53	1.70	5.22	17.83	3.05	10.41	1.74	5.09	17.38	3.00	10.24	1.84		
		75°F 24°C	5.99	20.45	4.10	13.98	3.84	13.09	1.70	5.27	17.97	3.79	12.92	1.75	4.86	16.59	3.54	12.08	1.91		
		81°F 27°C	5.98	20.42	4.73	16.14	4.50	15.36	1.69	5.23	17.83	4.45	15.19	1.74	5.07	17.30	4.35	14.85	1.85		
		86°F 30°C	6.05	20.64	5.56	18.98	5.41	18.46	1.69	5.27	18.00	5.27	18.00	1.75	5.11	17.43	5.11	17.43	1.85		
61°F [16°C]	WBE DBE	70°F 21°C	4.98	17.00	3.50	11.94	3.18	10.84	1.67	4.31	14.69	3.14	10.71	1.74	4.02	13.72	3.01	10.25	1.89		
		75°F 24°C	5.01	17.09	4.24	14.48	3.96	13.52	1.68	4.32	14.73	3.91	13.34	1.74	4.12	14.07	3.82	13.03	1.88		
		81°F 27°C	5.12	17.48	5.10	17.40	4.54	15.51	1.69	4.47	15.26	4.47	15.26	1.75	4.28	14.62	4.28	14.62	1.88		
		86°F 30°C	5.28	18.00	5.28	18.00	4.82	16.45	1.69	4.72	16.10	4.72	16.10	1.75	4.61	15.71	4.61	15.71	1.87		
72°F [22°C]	WBE DBE	75°F 24°C	5.48	18.69	3.50	11.95	3.17	10.82	1.70	4.67	15.93	3.13	10.66	1.75	4.51	15.39	3.06	10.43	1.87		
		81°F 27°C	5.47	18.68	4.41	15.03	3.66	14.41	1.70	4.74	16.16	4.11	14.01	1.76	4.54	15.50	3.99	13.62	1.87		
		86°F 30°C	5.49	18.72	5.14	17.52	4.91	16.74	1.70	4.76	16.24	4.76	16.24	1.75	4.59	15.67	4.59	15.67	1.87		
		91°F 33°C	5.55	18.94	5.55	18.94	5.10	17.40	1.70	5.02	17.13	5.02	17.13	1.75	4.88	16.65	4.88	16.65	1.88		
72°F [22°C]	WBE DBE	70°F 21°C	6.11	20.85	3.50	11.95	3.32	10.96	1.72	5.23	17.83	3.13	10.67	1.76	5.07	17.29	3.06	10.46	1.87		
		75°F 24°C	6.07	20.71	4.23	14.43	3.97	13.53	1.72	5.29	18.05	3.97	13.54	1.76	5.09	17.37	3.89	13.27	1.86		
		81°F 27°C	6.11	20.83	5.03	17.18	4.78	16.31	1.72	5.29	18.04	4.75	16.20	1.77	5.09	17.36	4.65	15.86	1.86		
		86°F 30°C	6.16	21.02	6.03	20.56	5.48	18.71	1.72	5.38	18.37	5.38	18.37	1.76	5.22	17.81	5.22	17.81	1.88		

[ ] Designates Metric Conversions

DBE - Entering air dry bulb  
WBE - Entering air wet bulb  
Power Input kW - Total Power Input

**GROSS SYSTEMS PERFORMANCE DATA - SAGN-024TA+EL3T2412SPBCTA**

Indoor		Outdoor Ambient Temperature, DB																					
		95°F [35°C]				115°F [46°C]				118°F [48°C]				126°F [52°C]									
Air Flow - CFM [L/s]	WBE	DBE	Total Capacity		Sensible Capacity		Power Input		Total Capacity		Sensible Capacity		Power Input		Total Capacity		Sensible Capacity		Power Input				
			kW	MBH	kW	MBH	kW	MBH	kW	MBH	kW	MBH	kW	MBH	kW	MBH	kW	MBH	kW	MBH	kW	MBH	
650 [307]	61°F [16°C]	70°F	5.59	19.06	3.90	13.30	1.40	4.84	16.52	3.50	11.95	1.72	4.73	16.15	3.45	11.76	1.76	4.52	15.43	3.35	11.44	1.88	
		75°F	5.54	18.90	4.72	16.09	1.40	4.88	16.65	4.30	14.67	1.72	4.77	16.28	4.32	14.75	1.76	4.57	15.59	4.15	14.17	1.90	
		81°F	5.63	19.21	5.63	19.21	1.39	5.04	17.19	5.04	17.19	1.72	4.98	16.99	4.98	16.99	1.79	4.76	16.25	4.76	16.25	1.89	
	66°F [19°C]	75°F	5.95	20.29	5.95	20.29	1.40	5.37	18.31	5.37	18.31	1.73	5.27	17.97	5.27	17.97	1.79	5.08	17.32	5.08	17.32	1.90	
		81°F	6.14	20.95	4.92	16.78	1.41	5.38	18.48	3.59	12.26	1.74	5.30	18.08	3.54	12.09	1.79	5.03	17.18	3.39	11.55	1.89	
		86°F	6.08	20.74	5.75	19.61	1.41	5.45	18.59	4.58	15.62	1.73	5.39	18.39	5.39	18.39	1.78	5.12	17.46	5.12	17.46	1.88	
	72°F [22°C]	81°F	6.76	23.06	3.88	13.24	1.42	5.95	20.30	3.53	12.05	1.75	5.87	20.02	3.50	11.93	1.81	5.67	19.36	3.42	11.68	1.88	
		86°F	6.82	23.27	4.76	16.23	1.43	6.02	20.56	4.43	15.11	1.76	5.90	20.14	4.41	15.05	1.80	5.78	19.73	4.36	14.89	1.88	
		91°F	6.79	23.18	5.60	19.10	1.42	6.07	20.73	5.33	18.20	1.75	5.91	20.15	5.28	18.01	1.80	5.72	19.52	5.18	17.68	1.88	
	700 [330]	61°F [16°C]	70°F	5.58	19.02	3.97	13.54	1.41	4.87	16.82	3.58	12.21	1.74	4.82	16.43	3.64	12.40	1.79	4.53	15.45	3.42	11.67	1.89
			75°F	5.58	19.04	4.88	16.64	1.41	4.91	16.75	4.47	15.26	1.73	4.83	16.47	4.52	15.41	1.78	4.60	15.68	4.36	14.87	1.89
			81°F	5.65	19.30	5.65	19.30	1.41	5.14	17.55	5.14	17.55	1.75	5.05	17.25	5.05	17.25	1.81	4.90	16.73	4.90	16.73	1.92
66°F [19°C]		75°F	6.03	20.57	6.03	20.57	1.41	5.49	18.75	5.49	18.75	1.75	5.38	18.37	5.38	18.37	1.82	5.23	17.85	5.23	17.85	1.92	
		81°F	6.12	20.90	3.99	13.61	1.42	5.43	18.53	3.69	12.58	1.74	5.32	18.15	3.64	12.41	1.79	5.10	17.40	3.56	12.14	1.90	
		86°F	6.13	20.93	5.04	17.20	1.42	5.44	18.56	4.78	16.32	1.75	5.31	18.12	4.72	16.09	1.79	5.11	17.44	4.59	15.66	1.89	
72°F [22°C]		81°F	6.38	21.76	6.38	21.76	1.42	5.84	19.94	5.84	19.94	1.75	5.74	19.59	5.74	19.59	1.81	5.55	18.93	5.55	18.93	1.91	
		86°F	6.77	23.12	3.94	13.43	1.43	6.03	20.56	3.64	12.41	1.77	5.89	20.09	3.58	12.23	1.82	5.77	19.67	3.57	12.20	1.90	
		91°F	6.96	23.75	4.96	16.93	1.44	6.06	20.66	4.55	15.52	1.77	5.94	20.28	4.56	15.56	1.81	5.77	19.68	4.50	15.34	1.90	
783 [370]		61°F [16°C]	70°F	6.88	23.47	5.80	19.78	1.43	6.08	20.74	5.49	18.74	1.76	5.97	20.37	5.48	18.70	1.81	5.77	19.68	5.39	18.40	1.89
			75°F	6.93	23.65	6.89	23.50	1.43	6.20	21.15	6.20	21.15	1.77	6.08	20.76	6.08	20.76	1.82	5.88	20.07	5.88	20.07	1.89
			81°F	5.59	19.09	4.08	13.92	1.45	4.90	16.72	3.75	12.79	1.78	4.79	16.35	3.66	12.49	1.82	4.60	15.71	3.61	12.31	1.94
	66°F [19°C]	75°F	5.62	19.17	5.08	17.34	1.45	4.95	16.89	4.77	16.27	1.78	4.82	16.46	4.60	15.68	1.82	4.65	15.87	4.53	15.47	1.93	
		81°F	5.84	19.94	5.84	19.94	1.45	5.26	17.96	5.26	17.96	1.79	5.15	17.58	5.15	17.58	1.85	4.98	17.00	4.98	17.00	1.96	
		86°F	6.20	21.15	6.20	21.15	1.47	5.58	19.04	5.58	19.04	1.79	5.47	18.65	5.47	18.65	1.86	5.31	18.13	5.31	18.13	1.96	
	72°F [22°C]	75°F	6.21	21.18	4.13	14.11	1.46	5.40	18.42	3.72	12.70	1.79	5.28	18.00	3.67	12.52	1.84	5.06	17.26	3.57	12.19	1.94	
		81°F	6.15	20.97	5.26	17.95	1.47	5.45	18.58	4.97	16.96	1.79	5.32	18.14	4.83	16.47	1.84	5.10	17.40	4.82	16.44	1.94	
		86°F	6.21	21.20	6.21	21.20	1.46	5.54	18.92	5.54	18.92	1.79	5.45	18.60	5.45	18.60	1.85	5.25	17.92	5.25	17.92	1.94	
	72°F [22°C]	75°F	6.60	22.52	6.60	22.52	1.47	5.98	20.40	5.98	20.40	1.80	5.86	20.01	5.86	20.01	1.85	5.67	19.35	5.67	19.35	1.95	
		81°F	6.80	23.21	4.05	13.82	1.47	6.03	20.56	3.75	12.79	1.82	5.86	20.00	3.68	12.57	1.86	5.81	19.82	3.69	12.60	1.93	
		86°F	6.82	23.27	5.10	17.41	1.48	6.07	20.71	4.80	16.37	1.81	5.98	20.42	4.78	16.30	1.87	5.80	19.78	4.70	16.02	1.94	
72°F [22°C]	75°F	6.96	23.74	6.15	20.97	1.48	6.11	20.84	5.83	19.89	1.80	6.02	20.53	5.76	19.65	1.87	5.80	19.80	5.64	19.24	1.94		
	81°F	6.99	23.84	6.99	23.84	1.48	6.26	21.36	6.26	21.36	1.81	6.16	21.02	6.16	21.02	1.87	6.01	20.52	6.01	20.52	1.94		
	86°F	6.99	23.84	6.99	23.84	1.48	6.26	21.36	6.26	21.36	1.81	6.16	21.02	6.16	21.02	1.87	6.01	20.52	6.01	20.52	1.94		

[ ] Designates Metric Conversions

DBE — Entering air dry bulb  
WBE — Entering air wet bulb  
Power Input kW - Total Power Input

**GROSS SYSTEMS PERFORMANCE DATA - SAGN-030TA+EL3T3012SPBCTA**

Air Flow - CFM [L/s]	Indoor		Outdoor Ambient Temperature, DB																			
	WBE	DBE	95°F [35°C]				115°F [46°C]				118°F [48°C]				126°F [52°C]							
			Total Capacity kW	MBH	Sensible Capacity kW	Power Input kW	Total Capacity kW	MBH	Sensible Capacity kW	Power Input kW	Total Capacity kW	MBH	Sensible Capacity kW	Power Input kW	Total Capacity kW	MBH	Sensible Capacity kW	Power Input kW				
1021 [482]	70°F	21°C	7.26	24.76	4.84	16.52	1.96	6.40	21.84	4.43	15.12	2.51	6.23	21.25	4.35	14.84	2.60	5.86	19.99	4.17	14.24	2.85
	75°F	24°C	7.26	24.76	5.83	19.90	1.96	6.40	21.84	5.37	18.32	2.51	6.29	21.45	5.35	18.25	2.59	5.87	20.03	5.14	17.52	2.86
	81°F	27°C	7.26	24.77	6.96	23.73	1.96	6.49	22.14	6.49	22.14	2.49	6.32	21.55	6.32	21.55	2.60	6.01	20.52	6.01	20.52	2.86
	86°F	30°C	7.32	24.98	7.32	24.98	1.96	6.72	22.94	7.32	22.94	2.51	6.62	22.59	6.62	22.59	2.61	6.49	22.15	6.49	22.15	2.82
	75°F	24°C	7.99	27.25	4.87	16.60	1.98	7.10	24.22	4.47	15.25	2.52	6.96	23.74	4.41	15.04	2.60	6.55	22.35	4.23	14.43	2.86
	81°F	27°C	7.98	27.24	6.06	20.66	1.98	7.09	24.20	5.64	19.25	2.52	6.97	23.77	5.59	19.06	2.60	6.53	22.26	5.34	18.22	2.87
	86°F	30°C	7.99	27.28	7.00	23.90	1.98	7.10	24.23	6.53	22.28	2.52	6.97	23.78	6.56	22.37	2.60	6.59	22.50	6.39	21.81	2.86
	91°F	33°C	7.98	27.21	7.98	27.21	1.97	7.19	24.55	7.19	24.55	2.51	7.08	24.14	7.08	24.14	2.60	6.70	22.85	6.70	22.85	2.85
	81°F	27°C	8.93	30.48	4.86	16.58	2.00	8.00	27.29	4.49	15.32	2.53	7.81	26.63	4.41	15.04	2.64	7.36	25.10	4.23	14.45	2.90
	86°F	30°C	9.00	30.72	5.89	20.11	2.01	7.98	27.23	5.49	18.73	2.52	7.80	26.80	5.41	18.46	2.63	7.33	25.00	5.24	17.86	2.90
	91°F	33°C	8.97	30.62	6.86	23.41	2.01	8.00	27.29	6.46	22.05	2.53	7.87	26.86	6.41	21.88	2.63	7.49	25.54	6.26	21.36	2.86
	97°F	36°C	8.96	30.57	8.00	27.29	2.00	8.01	27.32	7.65	26.10	2.53	7.86	26.83	7.60	25.94	2.61	7.51	25.63	7.46	25.46	2.85
1077 [508]	70°F	21°C	7.38	25.19	5.04	17.20	2.00	6.50	22.17	4.61	15.74	2.53	6.37	21.75	4.55	15.53	2.62	5.97	20.37	4.37	14.89	2.88
	75°F	24°C	7.39	25.20	6.08	20.75	2.00	6.50	22.17	5.67	19.36	2.53	6.38	21.77	5.62	19.16	2.63	6.00	20.46	5.44	18.55	2.87
	81°F	27°C	7.41	25.27	7.41	25.27	2.00	6.62	22.59	6.62	22.59	2.53	6.42	21.91	6.42	21.91	2.63	6.11	20.84	6.11	20.84	2.88
	86°F	30°C	7.64	26.05	7.64	26.05	2.00	7.05	24.04	7.05	24.04	2.56	6.94	23.69	6.94	23.69	2.65	6.73	22.98	6.73	22.98	2.84
	75°F	24°C	8.07	27.54	5.03	17.16	2.01	7.20	24.56	4.65	15.86	2.55	7.05	24.06	4.58	15.64	2.63	6.63	22.61	4.41	15.03	2.89
	81°F	27°C	8.12	27.71	6.34	21.72	2.01	7.19	24.54	5.93	20.23	2.55	7.05	24.06	5.88	20.05	2.63	6.63	22.63	5.71	19.47	2.90
	86°F	30°C	8.16	27.84	7.44	25.40	2.01	7.23	24.67	6.96	23.73	2.55	7.11	24.26	7.01	23.91	2.64	6.59	22.49	6.59	22.49	2.88
	91°F	33°C	8.26	28.19	8.26	28.19	2.02	7.36	25.12	7.36	25.12	2.54	7.27	24.79	7.27	24.79	2.64	6.95	23.71	6.95	23.71	2.88
	81°F	27°C	9.12	31.11	5.07	17.30	2.05	8.12	27.71	4.68	15.96	2.57	7.92	27.03	4.60	15.69	2.68	7.42	25.32	4.41	15.05	2.92
	86°F	30°C	9.03	30.81	6.14	20.94	2.04	8.12	27.71	5.77	19.70	2.57	7.92	27.02	5.70	19.44	2.68	7.56	25.79	5.56	18.96	2.89
	91°F	33°C	9.06	30.92	7.21	24.61	2.04	8.13	27.74	6.84	23.34	2.57	7.96	27.16	6.75	23.04	2.66	7.59	25.89	6.66	22.72	2.88
	97°F	36°C	9.13	31.16	8.55	29.16	2.04	8.17	27.86	8.15	27.81	2.57	8.05	27.48	8.05	27.48	2.66	7.64	26.07	7.64	26.07	2.89
1175 [555]	70°F	21°C	7.56	25.80	5.47	18.66	2.09	6.65	22.89	5.04	17.20	2.63	6.50	22.18	4.97	16.96	2.73	6.09	20.78	4.78	16.32	2.96
	75°F	24°C	7.61	25.98	6.78	23.14	2.11	6.69	22.82	6.35	21.66	2.63	6.53	22.28	6.27	21.38	2.72	6.08	20.74	5.94	20.27	2.98
	81°F	27°C	7.66	26.15	7.66	26.15	2.10	6.97	23.79	6.97	23.79	2.65	6.83	23.29	6.83	23.29	2.74	6.64	22.65	6.64	22.65	2.96
	86°F	30°C	8.40	28.65	8.40	28.65	2.12	7.57	25.83	7.57	25.83	2.67	7.44	25.37	7.44	25.37	2.76	7.10	24.24	7.10	24.24	2.96
	75°F	24°C	8.38	28.58	5.52	18.82	2.13	7.36	25.11	5.08	17.33	2.65	7.21	24.59	5.02	17.12	2.74	6.73	22.95	4.77	16.29	2.96
	81°F	27°C	8.40	28.67	7.09	24.18	2.12	7.35	25.09	6.63	22.62	2.65	7.26	24.78	6.59	22.48	2.74	6.85	23.38	6.42	21.90	2.97
	86°F	30°C	8.42	28.74	8.36	28.54	2.12	7.46	25.45	7.46	25.45	2.66	7.35	25.08	7.35	25.08	2.73	6.98	23.82	6.98	23.82	2.97
	91°F	33°C	8.79	29.99	8.79	29.99	2.13	7.86	26.82	7.86	26.82	2.66	7.74	26.41	7.74	26.41	2.75	7.39	25.23	7.39	25.23	2.97
	81°F	27°C	9.35	31.91	5.52	18.84	2.15	8.29	28.30	5.11	17.44	2.68	8.08	27.58	5.03	17.17	2.77	7.62	25.99	4.80	16.36	2.98
	86°F	30°C	9.36	31.93	6.86	23.42	2.15	8.28	28.25	6.41	21.87	2.67	8.08	27.58	6.36	21.71	2.77	7.86	26.81	6.27	21.41	2.93
	91°F	33°C	9.38	32.00	8.15	27.81	2.15	8.36	28.52	7.73	26.39	2.68	8.12	27.69	7.64	26.06	2.76	7.87	26.85	7.60	25.95	2.92
	97°F	36°C	9.48	32.34	9.48	32.34	2.16	8.44	28.79	8.44	28.79	2.68	8.28	28.26	8.28	28.26	2.77	8.14	27.78	8.14	27.78	2.94

[ ] Designates Metric Conversions

DBE — Entering air dry bulb  
WBE — Entering air wet bulb  
Power Input kW - Total Power Input

**GROSS SYSTEMS PERFORMANCE DATA - SAGN-036TA+EL3T3612SPBCTA**

Air Flow - CFM [L/s]	Indoor		Outdoor Ambient Temperature, DB												Power Input kW							
	WBE	DBE	95°F [35°C]				115°F [46°C]				118°F [48°C]					126°F [52°C]						
			Total Capacity kW	Sensible Capacity kW	MBH	Power Input kW	Total Capacity kW	Sensible Capacity kW	MBH	Power Input kW	Total Capacity kW	Sensible Capacity kW	MBH	Power Input kW		Total Capacity kW	Sensible Capacity kW	MBH				
980 [467]	70°F	21°C	8.66	29.57	5.88	20.08	2.74	7.62	26.01	5.38	18.35	3.44	7.47	25.49	5.30	18.10	3.57	6.94	23.67	5.04	17.20	3.91
	75°F	24°C	8.63	29.46	7.11	24.28	2.74	7.61	25.98	6.59	22.49	3.43	7.47	25.48	6.52	22.24	3.57	6.99	23.84	6.32	21.57	3.91
	81°F	27°C	8.65	29.52	8.57	29.23	2.73	7.72	26.35	7.72	26.35	3.44	7.54	25.74	7.54	25.74	3.56	7.09	24.18	7.09	24.18	3.91
	86°F	30°C	8.97	30.61	8.97	30.61	2.74	8.03	27.42	8.03	27.42	3.43	7.83	26.70	7.83	26.70	3.55	7.49	25.55	7.49	25.55	3.92
	75°F	24°C	9.52	32.49	5.91	20.16	2.73	8.47	28.88	5.43	18.54	3.43	8.34	28.47	5.38	18.35	3.56	7.74	26.42	5.12	17.48	3.92
	81°F	27°C	9.51	32.45	7.40	25.27	2.74	8.45	28.84	6.93	23.65	3.44	8.27	28.21	6.85	23.37	3.57	7.76	26.48	6.85	22.70	3.92
	86°F	30°C	9.57	32.66	8.66	29.55	2.74	8.47	28.91	8.14	27.77	3.43	8.31	28.34	8.06	27.50	3.56	7.82	26.69	7.82	26.69	3.99
	91°F	33°C	9.66	32.97	9.66	32.97	2.74	8.61	29.38	8.61	29.38	3.43	8.48	29.93	8.48	29.93	3.55	8.15	27.80	8.15	27.80	3.84
	81°F	27°C	10.74	36.65	5.96	20.32	2.75	9.63	32.52	5.47	18.66	3.45	9.37	31.97	5.40	18.44	3.55	8.75	29.85	5.16	17.60	3.89
	86°F	30°C	10.73	36.62	7.21	24.60	2.76	9.51	32.45	6.72	22.93	3.44	9.36	31.93	6.66	22.73	3.57	8.79	30.01	6.44	21.97	3.89
	91°F	33°C	10.72	36.58	8.45	28.82	2.74	9.54	32.54	8.01	27.33	3.43	9.35	31.91	7.90	26.97	3.55	8.80	30.02	7.69	26.23	3.89
	97°F	36°C	10.73	36.60	9.90	33.78	2.75	9.55	32.60	9.41	32.12	3.42	9.41	32.12	9.38	32.00	3.57	8.89	30.33	8.89	30.33	3.88
1050 [496]	70°F	21°C	8.69	29.67	5.98	20.40	2.77	7.67	26.17	5.48	18.70	3.46	7.43	25.34	5.37	18.31	3.60	7.01	23.91	5.17	17.64	3.92
	75°F	24°C	8.71	29.73	7.29	24.87	2.76	7.62	26.01	6.73	22.96	3.46	7.53	25.68	6.71	22.91	3.60	7.00	23.89	6.43	21.95	3.92
	81°F	27°C	8.67	29.57	8.67	29.57	2.76	7.79	26.59	7.79	26.59	3.47	7.56	25.81	7.56	25.81	3.59	7.21	24.61	7.21	24.61	3.95
	86°F	30°C	9.11	31.08	9.11	31.08	2.77	8.20	27.99	8.20	27.99	3.48	8.00	27.30	8.00	27.30	3.58	7.81	26.65	7.81	26.65	3.94
	75°F	24°C	9.64	32.88	6.04	20.60	2.77	8.48	28.92	5.52	18.84	3.47	8.33	28.42	5.46	18.62	3.60	7.77	26.50	5.22	17.80	3.95
	81°F	27°C	9.64	32.88	7.61	25.97	2.77	8.49	28.97	7.09	24.19	3.48	8.28	28.25	7.00	23.90	3.60	7.77	26.50	6.78	23.14	3.95
	86°F	30°C	9.63	32.84	8.86	30.23	2.78	8.52	29.06	8.37	28.56	3.47	8.35	28.48	8.28	28.26	3.60	7.85	26.79	7.85	26.79	3.94
	91°F	33°C	9.74	33.25	9.74	33.25	2.77	8.73	29.78	8.73	29.78	3.46	8.66	29.53	8.66	29.53	3.59	8.27	28.20	8.27	28.20	3.87
	81°F	27°C	10.86	37.05	6.08	20.75	2.80	9.55	32.60	5.56	18.98	3.48	9.41	32.11	5.50	18.78	3.59	8.84	30.18	5.28	18.02	3.94
	86°F	30°C	10.84	36.98	7.39	25.23	2.79	9.55	32.58	6.88	23.47	3.47	9.40	32.08	6.82	23.27	3.58	8.84	30.15	6.60	22.51	3.93
	91°F	33°C	10.85	37.01	8.70	29.69	2.80	9.64	32.81	8.25	28.15	3.47	9.41	32.09	8.12	27.72	3.59	8.84	30.16	7.88	26.88	3.93
	97°F	36°C	10.87	37.08	10.21	34.85	2.79	9.67	32.98	9.67	32.98	3.48	9.47	32.31	9.47	32.31	3.59	8.95	30.53	8.95	30.53	3.93
1140 [538]	70°F	21°C	8.85	30.19	6.23	21.25	2.82	7.67	26.16	5.62	19.18	3.50	7.63	25.02	5.65	19.26	3.64	7.08	24.17	5.39	18.39	3.97
	75°F	24°C	8.84	30.18	7.65	26.09	2.82	7.75	26.45	7.12	24.30	3.52	7.61	25.98	7.01	23.93	3.64	7.09	24.18	6.82	23.27	3.97
	81°F	27°C	8.94	30.49	8.94	30.49	2.82	7.98	27.24	7.98	27.24	3.51	7.86	26.82	7.86	26.82	3.63	7.43	25.37	7.43	25.37	4.01
	86°F	30°C	9.40	32.08	9.40	32.08	2.82	8.40	28.66	8.40	28.66	3.52	8.56	29.19	8.56	29.19	3.63	8.14	27.76	8.14	27.76	3.99
	75°F	24°C	9.78	33.36	6.28	21.43	2.83	8.55	29.18	5.72	19.53	3.50	8.42	28.73	5.68	19.39	3.63	7.93	27.07	5.47	18.68	3.98
	81°F	27°C	9.77	33.32	7.99	27.25	2.82	8.62	29.42	7.50	25.59	3.53	8.38	28.59	7.37	25.15	3.64	7.87	26.86	7.15	24.41	3.97
	86°F	30°C	9.81	33.47	9.37	31.97	2.82	8.61	29.38	8.61	29.38	3.53	8.48	28.92	8.48	28.92	3.64	8.00	27.28	8.00	27.28	3.98
	91°F	33°C	10.00	34.11	10.00	34.11	2.82	9.03	30.83	9.03	30.83	3.50	8.88	30.29	8.88	30.29	3.64	8.51	29.04	8.51	29.04	3.93
	81°F	27°C	10.94	37.34	6.30	21.50	2.83	9.65	32.94	5.79	19.75	3.51	9.51	32.44	5.73	19.55	3.62	8.93	30.47	5.51	18.80	3.97
	86°F	30°C	10.93	37.30	7.73	26.39	2.84	9.70	33.10	7.24	24.72	3.53	9.48	32.36	7.16	24.43	3.63	8.92	30.44	6.93	23.64	3.97
	91°F	33°C	11.02	37.62	9.23	31.50	2.84	9.72	33.16	8.62	29.41	3.52	9.52	32.48	8.53	29.09	3.63	8.95	30.52	8.36	28.51	3.96
	97°F	36°C	11.03	37.63	10.81	36.86	2.84	9.85	33.61	9.85	33.61	3.53	9.68	33.02	9.68	33.02	3.63	9.20	31.38	9.20	31.38	3.95

[ ] Designates Metric Conversions

DBE — Entering air dry bulb  
WBE — Entering air wet bulb  
Power Input kW - Total Power Input

**GROSS SYSTEMS PERFORMANCE DATA - SAGN-042NA+EL3T4217STACTA**

Indoor		Outdoor Ambient Temperature, DB																				
		95°F [35°C]				115°F [46°C]				118°F [48°C]				126°F [52°C]								
		WBE	DBE	Total Capacity	Sensible Capacity	Power Input	Total Capacity	Sensible Capacity	Power Input	Total Capacity	Sensible Capacity	Power Input	Total Capacity	Sensible Capacity	Power Input							
Air Flow - CFM [L/s]		kW	MBH	kW	MBH	kW	MBH	kW	MBH	kW	MBH	kW	MBH	kW	MBH							
930 [438]	61°F [16°C]	70°F 21°C	10.72	36.58	7.45	25.41	3.15	9.44	32.20	6.80	23.21	3.94	9.38	32.02	6.94	23.68	4.09	8.79	30.01	6.65	22.69	4.44
		75°F 24°C	10.80	36.84	9.17	31.30	3.16	9.53	32.52	8.54	29.13	3.95	9.31	31.78	8.57	29.24	4.11	8.78	29.97	8.35	28.50	4.56
		81°F 27°C	10.95	37.36	10.87	37.09	3.15	9.92	33.86	9.92	33.86	4.00	9.15	31.24	8.78	29.97	4.18	8.65	29.51	8.28	28.25	4.64
		86°F 30°C	11.58	39.51	11.58	39.51	3.13	10.45	35.67	10.45	35.67	3.96	9.05	30.87	9.05	30.87	4.19	8.67	29.60	8.67	29.60	4.57
		75°F 24°C	11.86	40.48	7.56	25.81	3.18	10.51	35.86	6.98	23.63	3.94	10.37	35.40	6.92	23.62	4.07	9.47	32.31	6.51	22.23	4.55
		81°F 27°C	11.83	40.38	9.52	32.49	3.19	10.49	35.81	8.99	30.66	3.93	10.29	35.11	8.90	30.35	4.07	9.51	32.44	8.59	29.30	4.57
		86°F 30°C	11.98	40.88	11.54	39.37	3.18	10.58	36.12	10.55	36.00	3.93	10.46	35.70	10.40	35.48	4.06	10.20	34.80	9.86	33.65	4.40
		91°F 33°C	12.12	41.36	12.12	41.36	3.18	11.14	38.00	11.14	38.00	3.98	10.96	37.39	10.96	37.39	4.17	10.59	36.13	10.59	36.13	4.47
		81°F 27°C	13.19	44.99	7.55	25.76	3.15	11.69	39.89	6.95	23.71	4.00	11.37	38.80	6.83	23.31	4.09	10.97	37.43	6.70	22.84	4.35
	86°F 30°C	13.25	45.22	9.27	31.62	3.14	11.83	40.37	8.63	29.46	3.98	11.49	39.20	8.54	29.15	4.07	11.04	37.66	8.36	28.54	4.35	
	91°F 33°C	13.27	45.27	11.12	37.96	3.15	11.75	40.08	10.39	35.44	3.98	11.53	39.35	10.20	34.79	4.08	11.03	37.63	9.98	34.06	4.34	
	97°F 36°C	13.38	45.66	12.99	44.33	3.14	11.89	40.57	11.89	40.57	3.98	11.52	39.32	11.52	39.32	4.13	10.98	37.48	10.94	37.34	4.45	
	70°F 21°C	10.99	37.49	7.90	26.97	3.21	9.73	33.20	7.32	24.96	3.99	9.41	32.12	7.13	24.33	4.15	8.95	30.54	6.91	23.58	4.49	
	75°F 24°C	11.03	37.63	9.90	33.80	3.20	9.76	33.31	9.18	31.33	4.05	9.54	32.57	9.15	31.23	4.13	8.96	30.58	8.84	30.17	4.47	
	81°F 27°C	11.34	38.68	11.34	38.68	3.19	10.23	34.92	10.23	34.92	4.03	9.57	32.65	9.38	31.99	4.16	9.18	31.34	8.99	30.67	4.53	
	86°F 30°C	12.00	40.96	12.00	40.96	3.22	10.87	37.10	10.87	37.10	3.99	9.68	33.04	9.68	33.04	4.13	9.47	32.32	9.47	32.32	4.49	
	75°F 24°C	12.05	41.12	8.07	27.53	3.23	10.65	36.35	7.40	25.24	3.99	10.49	35.80	7.33	25.00	4.12	9.87	32.00	7.06	24.09	4.48	
	81°F 27°C	12.04	41.07	10.11	34.50	3.23	10.68	36.46	9.68	33.02	4.05	10.45	35.66	9.58	32.70	4.17	9.88	33.72	9.34	31.85	4.53	
	86°F 30°C	12.24	41.76	12.17	41.52	3.22	10.86	37.07	10.86	37.07	4.03	10.76	36.73	10.68	36.43	4.17	10.29	35.11	10.13	34.55	4.51	
	91°F 33°C	12.69	43.28	12.69	43.28	3.22	11.57	39.49	11.57	39.49	3.99	11.31	38.60	11.31	38.60	4.20	10.88	37.13	10.88	37.13	4.49	
	81°F 27°C	13.57	46.29	8.15	27.79	3.23	11.92	40.67	7.36	25.10	4.03	11.76	40.14	7.29	24.88	4.15	11.13	37.99	7.05	24.04	4.51	
	86°F 30°C	13.46	45.92	9.80	33.44	3.19	11.84	40.39	9.16	31.26	4.03	11.67	39.83	9.10	31.05	4.14	11.12	37.93	8.86	30.23	4.38	
	91°F 33°C	13.55	46.22	11.77	40.17	3.23	11.93	40.71	11.21	38.26	4.02	11.67	39.80	11.07	37.78	4.13	11.04	37.66	10.80	36.86	4.49	
	97°F 36°C	13.71	46.78	13.71	46.78	3.23	12.15	41.47	12.15	41.47	4.00	11.93	40.72	11.93	40.72	4.11	11.36	38.76	11.36	38.76	4.46	
	70°F 21°C	11.07	37.78	8.20	28.00	3.27	9.69	33.07	7.56	25.80	4.12	9.46	32.27	7.36	25.10	4.20	8.86	30.22	7.07	24.13	4.53	
	75°F 24°C	11.17	38.11	10.27	35.04	3.26	9.87	33.67	9.53	32.52	4.12	9.60	32.74	9.33	31.82	4.21	9.11	31.09	9.01	30.76	4.55	
	81°F 27°C	11.67	39.83	11.67	39.83	3.29	10.51	35.85	10.51	35.85	4.07	9.80	32.74	9.46	32.29	4.24	9.12	31.13	8.99	30.68	4.62	
	86°F 30°C	12.39	42.27	12.39	42.27	3.30	11.19	38.17	11.19	38.17	4.10	9.69	33.05	9.69	33.05	4.27	9.22	31.46	9.22	31.46	4.65	
	75°F 24°C	12.21	41.67	8.34	28.44	3.29	10.65	36.35	7.62	26.00	4.10	9.56	32.62	6.34	21.64	4.19	9.02	30.79	6.11	20.85	4.54	
	81°F 27°C	12.28	41.88	10.80	36.86	3.29	10.73	36.61	10.21	34.85	4.11	10.18	34.74	8.02	27.37	4.34	9.62	32.83	7.78	26.56	4.69	
	86°F 30°C	12.36	42.16	12.36	42.16	3.29	11.10	37.88	11.10	37.88	4.10	10.94	37.33	10.94	37.33	4.28	10.41	35.51	10.41	35.51	4.64	
	91°F 33°C	13.13	44.82	13.13	44.82	3.26	11.89	40.58	11.89	40.58	4.10	11.59	39.55	11.59	39.55	4.25	11.19	38.17	11.19	38.17	4.56	
	81°F 27°C	13.48	45.99	8.28	28.24	3.30	11.92	40.68	7.64	26.06	4.09	11.23	38.31	7.37	25.14	4.27	10.59	36.13	7.12	24.30	4.73	
	86°F 30°C	13.55	46.22	10.36	35.33	3.29	11.98	40.86	9.67	32.98	4.07	11.40	39.90	9.00	30.71	4.37	10.78	36.77	8.74	29.83	4.71	
	91°F 33°C	13.63	46.52	12.41	42.33	3.29	11.84	40.41	11.84	40.41	4.08	11.76	40.13	11.71	39.94	4.25	11.52	39.30	11.13	37.97	4.59	
	97°F 36°C	13.90	47.42	13.90	47.42	3.28	12.65	43.16	12.65	43.16	4.12	11.92	40.69	11.92	40.69	4.16	11.39	38.87	11.39	38.87	4.49	

[ ] Designates Metric Conversions

DBE — Entering air dry bulb  
WBE — Entering air wet bulb  
Power Input kW - Total Power Input



**GROSS SYSTEMS PERFORMANCE DATA - SAGN-048NA+EL3T4817STACTA**

Air Flow - CFM [L/s]		Indoor				Outdoor Ambient Temperature, DB																	
		WBE	DBE	95°F [35°C]		115°F [46°C]		118°F [48°C]		126°F [52°C]		Power Input kW	Sensible Capacity MBH	Total Capacity kW	Power Input kW	Sensible Capacity MBH	Total Capacity kW						
				Total Capacity kW	Sensible Capacity kW	Total Capacity kW	Sensible Capacity kW	Total Capacity kW	Sensible Capacity kW	Total Capacity kW	Sensible Capacity kW												
1300 [613]	61°F [16°C]	70°F	21°C	12.17	41.53	8.47	28.91	3.75	10.85	37.03	7.91	27.00	4.65	10.57	36.08	7.79	26.59	4.77	10.26	34.99	7.69	26.26	5.07
		75°F	24°C	12.20	41.62	10.43	35.59	3.75	10.90	37.19	9.89	33.76	4.64	10.63	36.27	9.59	32.71	4.79	10.63	34.89	9.50	32.40	5.05
		81°F	27°C	12.39	42.26	12.39	42.26	3.75	11.00	37.53	11.00	37.53	4.64	10.82	36.90	10.82	36.90	4.79	10.49	35.78	10.49	35.78	5.05
		86°F	30°C	12.94	44.16	12.94	44.16	3.76	11.77	40.15	11.77	40.15	4.66	11.63	39.70	11.63	39.70	4.83	11.31	38.60	11.31	38.60	5.07
	66°F [19°C]	75°F	24°C	13.42	45.80	8.62	29.41	3.77	11.92	40.89	7.96	27.18	4.65	11.78	40.20	7.91	27.00	4.81	11.03	37.62	7.56	25.79	5.18
		81°F	27°C	13.36	45.59	10.89	37.17	3.78	11.75	40.11	10.14	34.60	4.65	11.74	40.06	10.22	34.86	4.82	11.13	37.96	9.89	33.76	5.17
		86°F	30°C	13.43	45.82	12.93	44.11	3.77	12.04	41.07	12.04	41.07	4.67	11.77	40.16	11.77	40.16	4.80	11.36	38.76	11.36	38.76	5.06
		91°F	33°C	13.56	46.26	13.56	46.26	3.78	12.37	42.22	12.37	42.22	4.68	12.15	41.45	12.15	41.45	4.83	11.60	39.58	11.60	39.58	5.20
	72°F [22°C]	75°F	24°C	14.96	51.06	8.58	29.29	3.82	13.23	45.13	7.90	26.97	4.68	12.91	44.05	7.78	26.55	4.84	12.59	42.94	7.70	26.26	5.06
		81°F	30°C	15.01	51.21	10.69	36.49	3.82	13.23	45.16	9.95	33.96	4.69	12.88	43.96	11.61	39.61	4.85	12.71	43.37	9.80	33.43	5.06
		86°F	33°C	14.94	50.97	12.49	42.63	3.82	13.25	45.22	11.69	39.89	4.69	12.88	43.96	11.61	39.61	4.85	12.65	43.15	11.51	39.27	5.06
		91°F	36°C	14.87	50.73	14.80	50.51	3.82	13.51	46.10	13.51	46.10	4.72	13.29	45.36	13.29	45.36	4.86	12.78	43.59	12.78	43.59	5.06
1450 [684]	70°F	21°C	12.41	42.33	8.99	30.66	3.80	10.97	37.43	8.33	28.43	4.70	10.74	36.65	8.23	28.08	4.84	10.31	35.17	7.96	27.15	5.09	
	75°F	24°C	12.44	42.46	11.09	37.85	3.81	10.97	37.44	10.44	35.61	4.70	10.74	36.66	10.18	34.73	4.84	10.26	35.01	10.12	34.53	5.10	
	81°F	27°C	12.51	42.70	12.51	42.70	3.81	11.39	38.86	11.39	38.86	4.72	11.15	38.05	11.15	38.05	4.86	10.83	37.31	10.93	37.31	5.11	
	86°F	30°C	13.41	45.76	13.41	45.76	3.82	12.23	41.72	12.23	41.72	4.72	12.04	41.08	12.04	41.08	4.86	11.69	39.90	11.69	39.90	5.15	
1609 [759]	75°F	24°C	13.63	46.50	8.99	30.68	3.84	12.04	41.07	8.34	28.45	4.71	11.89	40.58	8.26	28.19	4.88	11.33	38.67	7.96	27.16	5.11	
	81°F	27°C	13.49	46.01	11.41	38.94	3.83	12.04	41.08	10.84	36.98	4.72	11.81	40.31	10.75	36.69	4.87	11.11	37.90	10.31	35.19	5.22	
	86°F	30°C	13.69	46.70	13.69	46.70	3.83	12.17	41.54	12.17	41.54	4.72	12.02	41.01	12.02	41.01	4.88	11.41	38.93	11.41	38.93	5.27	
	91°F	33°C	13.95	47.60	13.95	47.60	3.85	12.67	43.22	12.67	43.22	4.72	12.57	42.89	12.57	42.89	4.90	12.23	41.75	12.23	41.75	5.27	
72°F [22°C]	81°F	27°C	15.16	51.73	8.97	30.59	3.88	13.42	45.79	8.34	28.44	4.75	13.28	45.31	8.26	28.18	4.90	12.82	43.73	8.27	28.21	5.12	
	86°F	30°C	15.06	51.37	11.05	37.69	3.87	13.40	45.74	10.41	35.52	4.75	13.16	44.91	10.28	35.06	4.91	12.80	43.67	10.21	34.83	5.12	
	91°F	33°C	15.00	51.17	13.18	44.96	3.88	13.44	45.85	12.49	42.63	4.76	13.20	45.03	12.65	43.15	4.90	12.74	43.48	12.22	41.69	5.09	
	97°F	36°C	15.21	51.91	15.21	51.91	3.88	13.73	46.85	13.73	46.85	4.75	13.53	46.16	13.53	46.16	4.90	13.17	44.94	13.17	44.94	5.13	
61°F [16°C]	70°F	21°C	12.59	42.95	9.36	31.94	3.89	11.00	37.53	8.65	29.51	4.77	10.78	36.77	8.50	29.01	4.92	10.50	35.82	8.49	28.98	5.19	
	75°F	24°C	12.81	43.70	11.51	39.28	3.87	11.15	38.05	11.05	37.71	4.78	10.91	37.24	10.91	37.24	4.92	10.52	35.89	10.52	35.89	5.20	
	81°F	27°C	12.81	43.70	12.81	43.70	3.88	11.75	40.08	11.75	40.08	4.80	11.61	39.60	11.61	39.60	4.95	11.25	38.40	11.25	38.40	5.20	
	86°F	30°C	13.75	46.92	13.75	46.92	3.91	12.52	42.73	12.52	42.73	4.81	12.29	41.95	12.29	41.95	4.94	12.01	40.97	12.01	40.97	5.23	
1609 [759]	75°F	24°C	13.77	46.98	9.36	31.89	3.91	12.24	41.77	8.72	29.75	4.80	11.95	40.76	8.60	29.35	4.95	11.43	38.99	8.36	28.53	5.21	
	81°F	27°C	13.66	46.59	11.87	40.49	3.91	12.19	41.58	11.43	39.00	4.80	11.83	40.37	11.24	38.34	4.93	11.46	39.11	11.09	37.83	5.20	
	86°F	30°C	13.95	47.61	13.95	47.61	3.92	12.36	42.18	12.36	42.18	4.79	12.14	41.42	12.14	41.42	4.93	11.59	39.53	11.59	39.53	5.32	
	91°F	33°C	14.32	48.88	14.32	48.88	3.93	13.18	44.97	13.18	44.97	4.82	13.03	44.46	13.03	44.46	4.95	12.60	42.99	12.60	42.99	5.37	
72°F [22°C]	81°F	27°C	15.10	51.52	9.28	31.66	3.96	13.45	45.90	8.66	29.56	4.83	13.10	44.70	8.53	29.11	4.98	12.85	43.83	8.44	28.79	5.19	
	86°F	30°C	15.16	51.73	11.49	39.21	3.96	13.54	46.21	10.95	37.35	4.84	13.28	45.30	10.84	36.99	5.00	12.86	43.87	10.69	36.48	5.19	
	91°F	33°C	15.31	52.24	13.95	47.61	3.96	13.57	46.32	13.20	45.04	4.83	13.36	45.59	13.26	45.26	4.98	12.94	44.15	12.94	44.15	5.17	
	97°F	36°C	15.40	52.54	15.40	52.54	3.95	14.14	48.26	14.14	48.26	4.85	13.78	47.02	13.78	47.02	4.99	13.47	45.96	13.47	45.96	5.20	

[ ] Designates Metric Conversions

DBE — Entering air dry bulb  
 WBE — Entering air wet bulb  
 Power Input kW - Total Power Input



**GROSS SYSTEMS PERFORMANCE DATA - SAGN-060NA+EL3T6017STACTA**

Indoor		Outdoor Ambient Temperature, DB																				
		95°F [35°C]				115°F [46°C]				118°F [48°C]				126°F [52°C]								
		WBE	DBE	Total Capacity kW	Sensible Capacity kW	Power Input kW	Total Capacity kW	Sensible Capacity kW	Power Input kW	Total Capacity kW	Sensible Capacity kW	Power Input kW	Total Capacity kW	Sensible Capacity kW	Power Input kW							
1750 [825]	61°F [16°C]	70°F 21°C	14.85	50.69	10.50	35.82	4.47	13.01	44.39	9.63	32.86	5.52	12.80	43.69	9.54	32.54	5.67	12.29	41.95	9.31	31.75	6.12
	75°F 24°C	75°F 24°C	14.66	50.02	12.68	43.26	4.46	13.05	44.52	12.00	40.93	5.50	12.80	43.68	11.89	40.56	5.67	12.27	41.86	11.70	39.93	6.11
	81°F 27°C	81°F 27°C	15.01	51.21	15.01	51.21	4.48	13.44	45.87	13.44	45.87	5.51	13.29	45.35	13.29	45.35	5.67	12.79	43.63	12.78	43.60	6.12
	86°F 30°C	86°F 30°C	15.62	53.30	15.62	53.30	4.47	14.41	49.17	14.41	49.17	5.52	14.20	48.47	14.20	48.47	5.69	14.10	48.12	14.10	48.12	5.80
	75°F 24°C	75°F 24°C	16.22	55.35	10.49	35.79	4.50	14.79	50.46	9.51	32.46	5.51	14.17	48.34	9.60	32.77	5.70	13.75	46.94	9.38	32.02	6.04
	81°F 27°C	81°F 27°C	16.18	55.22	13.41	45.75	4.49	14.79	50.46	12.45	42.50	5.51	14.16	48.31	12.50	42.67	5.70	13.78	47.02	12.39	42.28	6.02
	86°F 30°C	86°F 30°C	16.34	55.76	15.80	53.91	4.51	14.55	49.65	14.55	49.65	5.55	14.29	48.77	14.29	48.77	5.72	14.27	48.70	13.90	47.44	6.02
	91°F 33°C	91°F 33°C	16.66	56.85	16.66	56.85	4.50	15.28	52.13	15.28	52.13	5.53	14.92	50.92	14.92	50.92	5.72	14.45	49.30	14.45	49.30	6.04
	75°F 24°C	75°F 24°C	18.20	62.11	10.53	35.92	4.55	16.63	56.73	9.44	32.22	5.58	16.27	55.52	9.09	31.01	5.77	15.61	49.26	8.85	30.19	6.23
	81°F 27°C	81°F 27°C	18.04	61.55	12.95	44.18	4.53	16.56	56.52	11.90	40.62	5.58	16.21	55.31	11.55	39.41	5.77	15.54	53.01	11.21	38.25	6.23
	86°F 30°C	86°F 30°C	18.20	62.10	15.46	52.76	4.55	16.52	56.38	14.17	48.35	5.57	16.17	55.17	13.81	47.13	5.76	15.55	53.06	13.55	46.23	6.21
	91°F 33°C	91°F 33°C	18.32	62.52	18.32	62.50	4.55	16.65	56.81	16.65	56.81	5.56	16.29	55.59	16.29	55.59	5.75	16.03	54.72	15.65	53.39	6.22
1873 [883]	61°F [16°C]	70°F 21°C	14.81	50.55	10.66	36.36	4.59	13.04	44.51	9.83	33.53	5.63	12.74	43.49	9.67	32.99	5.75	12.12	41.37	9.35	31.92	6.21
	75°F 24°C	75°F 24°C	14.87	50.73	13.29	45.35	4.59	13.04	44.51	12.33	42.09	5.63	12.86	43.88	12.25	41.79	5.76	12.21	41.68	11.94	40.75	6.21
	81°F 27°C	81°F 27°C	15.17	51.76	15.17	51.76	4.60	13.59	46.36	13.59	46.36	5.60	13.45	45.88	13.45	45.88	5.77	13.32	45.46	13.31	45.41	5.90
	86°F 30°C	86°F 30°C	16.04	54.75	16.04	54.75	4.61	14.46	49.35	14.46	49.35	5.63	14.47	49.38	14.47	49.38	5.86	14.17	48.36	14.17	48.36	6.11
	75°F 24°C	75°F 24°C	16.26	55.47	10.68	36.45	4.62	14.44	49.29	9.28	31.65	5.60	14.20	48.45	9.80	33.43	5.82	13.74	46.87	9.63	32.86	6.11
	81°F 27°C	81°F 27°C	16.31	55.65	13.79	47.04	4.63	14.44	49.27	12.92	44.08	5.69	14.23	48.57	12.90	44.02	5.83	13.75	46.92	12.71	43.36	6.13
	86°F 30°C	86°F 30°C	16.39	55.93	16.26	55.48	4.62	14.61	49.86	14.61	49.86	5.66	14.37	49.03	14.37	49.03	5.85	14.14	48.25	13.87	47.32	6.14
	91°F 33°C	91°F 33°C	16.85	57.49	16.85	57.49	4.62	15.37	52.45	15.37	52.45	5.68	15.08	51.45	15.08	51.45	5.84	14.70	50.17	14.70	50.17	6.13
	75°F 24°C	75°F 24°C	18.20	62.09	10.69	36.49	4.67	16.52	56.37	9.52	32.49	5.70	16.23	55.37	9.23	31.49	5.86	15.47	52.80	8.93	30.48	6.34
	81°F 27°C	81°F 27°C	18.22	62.19	13.33	45.49	4.66	16.48	56.22	12.13	41.37	5.71	16.18	55.22	11.83	40.38	5.87	15.50	52.88	11.47	39.12	6.33
	86°F 30°C	86°F 30°C	18.27	62.35	15.58	53.16	4.67	16.52	56.36	14.66	50.03	5.70	16.22	55.36	14.37	49.03	5.86	15.58	53.16	14.30	48.81	6.31
	91°F 33°C	91°F 33°C	18.37	62.67	18.37	62.67	4.66	16.68	56.90	16.68	56.90	5.70	16.46	56.15	16.46	56.15	5.83	16.15	55.10	16.09	54.89	6.03
2015 [950]	61°F [16°C]	70°F 21°C	14.82	50.57	10.87	37.08	4.69	13.12	44.75	10.05	34.28	5.73	12.91	44.07	10.10	34.47	5.90	12.36	42.17	9.80	33.46	6.34
	75°F 24°C	75°F 24°C	14.90	50.85	13.55	46.24	4.70	13.18	44.99	12.75	43.50	5.72	12.89	43.97	12.61	43.03	5.92	12.30	41.98	12.26	41.85	6.35
	81°F 27°C	81°F 27°C	15.24	52.01	15.24	52.01	4.70	13.84	47.22	13.84	47.22	5.73	13.55	46.24	13.55	46.24	5.92	13.01	44.39	12.27	41.85	6.40
	86°F 30°C	86°F 30°C	16.49	56.25	16.49	56.25	4.74	15.01	51.21	15.01	51.21	5.75	14.64	49.94	14.64	49.94	5.99	14.22	48.53	13.43	45.82	6.54
	75°F 24°C	75°F 24°C	16.49	56.25	10.99	37.49	4.74	14.59	49.78	10.17	34.72	5.78	14.22	48.52	10.12	34.53	5.93	13.50	46.08	9.73	33.19	6.33
	81°F 27°C	81°F 27°C	16.38	55.90	14.23	48.56	4.73	14.52	49.55	13.42	45.80	5.78	14.21	48.50	13.22	45.10	5.92	13.47	47.66	12.93	44.11	6.31
	86°F 30°C	86°F 30°C	16.51	56.32	16.51	56.32	4.72	14.80	50.50	14.80	50.50	5.76	14.49	49.45	14.49	49.45	5.94	13.97	47.66	13.97	47.66	6.22
	91°F 33°C	91°F 33°C	17.19	58.65	17.19	58.65	4.75	15.66	53.42	15.66	53.42	5.78	15.38	52.47	15.38	52.47	5.96	15.02	51.24	15.02	51.24	6.24
	75°F 24°C	75°F 24°C	18.01	61.47	10.85	37.01	4.77	16.90	57.68	10.10	34.48	5.81	16.63	56.73	9.83	33.53	5.98	15.85	54.09	9.53	32.51	6.34
	81°F 27°C	81°F 27°C	18.26	62.30	13.71	46.77	4.77	16.88	57.61	12.85	43.84	5.80	16.61	56.66	12.57	42.89	5.98	16.23	55.37	12.38	42.25	6.17
	86°F 30°C	86°F 30°C	18.28	62.36	16.35	55.78	4.77	16.92	57.74	15.55	53.08	5.81	16.64	56.79	15.28	42.93	5.99	16.26	55.50	15.07	51.41	6.18
	91°F 33°C	91°F 33°C	18.42	62.85	18.42	62.85	4.76	17.30	59.02	17.30	59.02	5.84	16.58	56.58	16.58	56.58	5.94	16.22	55.33	16.22	55.33	6.13

[ ] Designates Metric Conversions

DBE — Entering air dry bulb  
WBE — Entering air wet bulb  
Power Input kW - Total Power Input

**GROSS SYSTEMS PERFORMANCE DATA - SAGN-065NA+EL3T6518STACTA**

Air Flow - CFM [L/s]		Indoor				Outdoor Ambient Temperature, DB																
		WBE	DBE	95°F [35°C]			115°F [46°C]			118°F [48°C]			126°F [52°C]									
				Total Capacity kW	Sensible Capacity MBH	Power Input kW	Total Capacity kW	Sensible Capacity MBH	Power Input kW	Total Capacity kW	Sensible Capacity MBH	Power Input kW	Total Capacity kW	Sensible Capacity MBH	Power Input kW							
2203 [1039]	61°F [16°C]	70°F	16.25	55.44	12.04	41.08	4.61	14.39	49.10	11.18	38.14	5.65	13.74	46.89	11.18	38.72	5.72	13.59	46.54	10.87	37.06	6.03
		75°F	16.18	55.20	14.99	51.14	4.63	14.18	48.38	13.69	46.70	5.62	13.74	46.88	13.53	46.74	5.72	13.57	46.45	13.26	45.24	6.02
		81°F	16.57	56.55	16.57	56.55	4.62	15.13	51.64	15.13	51.64	5.61	14.93	51.53	14.23	48.55	5.72	14.35	48.94	14.08	48.19	6.03
		86°F	17.90	61.07	17.90	61.07	4.61	16.47	56.20	16.47	56.20	5.63	15.84	54.85	15.14	51.87	5.74	15.66	53.43	15.40	52.71	5.71
	66°F [19°C]	75°F	17.76	60.62	12.03	41.04	4.61	16.19	55.24	11.03	37.63	5.61	15.11	51.54	11.24	38.95	5.75	15.05	51.53	10.94	37.33	5.95
		81°F	17.65	60.23	15.52	52.95	4.62	16.12	55.01	14.48	49.43	5.61	15.10	51.51	14.14	48.85	5.75	15.08	51.61	13.95	47.59	5.93
		86°F	17.99	61.38	17.99	61.38	4.63	16.16	55.15	16.12	55.00	5.63	15.93	54.95	15.23	51.97	5.77	15.83	54.01	15.20	52.03	5.93
		91°F	18.70	63.82	18.70	63.82	4.64	17.16	58.56	17.16	58.56	5.60	16.56	57.10	15.86	54.12	5.77	16.01	54.61	15.75	53.89	5.95
	72°F [22°C]	75°F	20.02	68.32	12.11	41.32	4.62	18.07	61.65	10.88	37.13	5.64	17.21	58.72	10.73	37.19	5.82	16.91	57.85	10.41	35.50	6.14
		81°F	19.89	67.86	15.14	51.65	4.62	18.13	61.86	14.00	47.76	5.64	17.15	58.51	13.19	45.59	5.82	16.84	57.60	12.77	43.56	6.14
		86°F	19.93	68.00	18.09	61.73	4.63	18.09	61.72	16.89	57.63	5.63	17.11	58.37	15.45	53.31	5.81	16.85	57.65	15.11	51.54	6.12
		97°F	20.04	68.36	20.04	68.36	4.63	18.55	63.29	18.55	63.29	5.61	17.93	61.77	17.23	58.79	5.80	17.59	60.03	16.95	57.98	6.13
2250 [1061]	61°F [16°C]	70°F	16.33	55.73	12.28	41.90	4.65	14.32	48.86	11.22	38.28	5.68	13.68	46.69	11.31	39.17	5.80	13.42	45.96	10.91	37.23	6.12
		75°F	16.08	54.88	15.06	51.37	4.66	14.35	48.95	14.23	48.57	5.69	13.89	47.97	13.80	47.08	5.81	13.51	46.27	13.50	46.06	6.12
		81°F	16.67	56.89	16.67	56.89	4.65	14.99	51.15	14.99	51.15	5.63	15.09	52.06	14.39	49.08	5.82	14.88	50.77	14.61	50.00	5.81
		86°F	17.91	61.10	17.91	61.10	4.65	16.19	55.26	16.19	55.26	5.65	16.11	55.56	15.41	52.58	5.91	15.73	53.67	15.47	52.95	6.02
72°F [22°C]	75°F	17.57	59.94	12.04	41.09	4.65	15.72	53.66	10.62	36.23	5.62	15.14	51.65	11.44	39.61	5.87	15.04	51.46	11.19	38.17	6.04	
	81°F	17.64	60.20	15.69	53.53	4.65	15.63	53.32	14.69	50.14	5.70	15.17	51.77	14.54	50.20	5.88	15.05	51.51	14.27	48.67	6.04	
	86°F	17.91	61.10	17.91	61.10	4.66	16.07	54.84	16.07	54.84	5.68	16.01	55.21	15.31	52.23	5.90	15.70	53.56	15.17	51.91	6.05	
	91°F	18.73	63.91	18.73	63.91	4.66	17.15	58.52	17.15	58.52	5.67	16.72	57.63	16.02	54.85	5.89	16.26	55.48	16.00	54.76	6.04	
2322 [1095]	61°F [16°C]	70°F	19.71	67.27	12.06	41.14	4.66	17.79	60.70	10.82	36.92	5.70	17.17	58.57	10.87	37.67	5.91	16.77	57.39	10.49	35.79	6.25
		75°F	19.83	67.68	15.25	52.04	4.66	18.09	61.72	14.06	47.96	5.70	17.12	58.42	13.47	46.56	5.92	16.80	57.47	13.03	44.43	6.24
		81°F	19.90	67.89	18.27	62.33	4.67	18.06	61.62	16.99	57.99	5.69	17.16	58.56	16.01	55.21	5.91	16.88	57.75	15.86	54.12	6.22
		97°F	21.23	72.54	19.97	67.99	4.67	18.92	64.55	18.92	64.55	5.70	18.10	62.33	17.40	59.35	5.88	17.71	60.41	17.39	59.48	5.94
75°F [24°C]	70°F	16.17	55.18	12.21	41.67	4.71	14.31	48.83	11.35	38.71	5.68	13.85	47.27	11.74	40.65	5.95	13.66	46.76	11.36	38.77	6.25	
	75°F	16.08	54.85	15.38	52.46	4.70	16.16	55.15	14.32	48.87	5.68	14.25	49.21	13.83	47.17	5.97	13.86	47.29	13.56	46.44	6.26	
	81°F	16.81	57.37	16.81	57.37	4.71	15.20	51.96	15.20	51.96	5.73	15.19	52.42	14.49	49.44	5.97	14.31	48.98	13.83	47.16	6.31	
	86°F	18.02	61.49	18.02	61.49	4.70	16.53	56.41	16.53	56.41	5.69	16.28	56.12	15.58	53.14	6.04	15.52	53.12	14.99	51.13	6.45	
81°F [27°C]	75°F	17.87	60.98	12.26	41.84	4.71	15.98	54.53	11.46	39.11	5.75	15.16	51.72	11.76	40.71	5.98	14.80	50.67	11.29	38.50	6.24	
	81°F	17.64	60.18	16.05	54.75	4.69	15.66	53.45	14.95	51.02	5.71	15.15	51.70	14.86	51.28	5.97	14.77	50.55	14.49	49.42	6.22	
	86°F	18.01	61.44	18.01	61.44	4.71	16.39	55.93	16.39	55.93	5.69	16.13	56.63	15.43	52.65	5.99	15.63	52.97	15.27	52.25	6.13	
	91°F	18.90	64.49	18.90	64.49	4.70	17.61	60.09	17.61	60.09	5.71	17.02	58.65	16.32	55.67	6.01	16.58	56.55	16.32	55.63	6.15	
86°F [30°C]	75°F	19.84	67.71	12.25	41.81	4.71	18.43	62.90	11.39	38.87	5.73	17.57	59.93	11.47	39.71	6.03	17.15	58.68	11.09	37.82	6.25	
	81°F	19.88	67.83	15.36	52.42	4.70	18.40	62.79	14.59	49.80	5.72	17.55	59.86	14.21	49.07	6.03	17.53	59.96	13.94	47.56	6.08	
	86°F	19.91	67.94	18.52	63.18	4.71	18.38	62.71	17.63	60.15	5.74	17.58	59.99	16.92	58.31	6.04	17.56	60.09	16.63	56.72	6.09	
	97°F	20.74	70.77	20.74	70.77	4.71	19.10	65.17	19.10	65.17	5.72	18.22	62.76	17.52	59.78	5.99	17.78	60.69	17.52	59.92	6.04	

[ ] Designates Metric Conversions

DBE — Entering air dry bulb  
WBE — Entering air wet bulb  
Power Input kW - Total Power Input



# AIRFLOW PERFORMANCE

Airflow performance data is based on cooling performance with a coil and filter in place. Select performance table for appropriate unit size voltage Make sure external static applied to unit allows operation within the minimum and maximum limits shown in table below for cooling operation.

## 5.2 AIRFLOW PERFORMANCE DATA - EL3T (50HZ WITH CONSTANT TORQUE MOTOR)

Model No. EL3T	Tonnage Application	Blower Size/ Motor HP [W] # of Speeds	Speed Tap	Torque Value lb*in [N*m]	CFM [L/s] Air Delivery/RPM/Watts -- 220-230 Volts					
					External Static Pressure -- Inches W.C. [kPa]					
					0.1 [.02]	0.2 [.05]	0.3 [.07]	0.4 [.10]	0.5 [.12]	
1812SP	1.5 Ton	6x8 1/3HP [249] 5 Speed	1	2.6 [.294]	SCFM	350	276	199	-	-
					RPM	872	990	1118	-	-
					Watts	36.1	41.1	45.6	-	-
			2	3.4 [.384]	SCFM	450	380	306	-	-
					RPM	983	1070	1182	-	-
					Watts	52.3	55.2	59.5	-	-
			3	3.8 [.429]	SCFM	490	429	354	-	-
					RPM	1018	1114	1216	-	-
					Watts	57.8	63.7	69.2	-	-
			4	4.2 [.475]	SCFM	525	472	407	-	-
					RPM	1074	1150	1245	-	-
					Watts	68.2	72.8	78.6	-	-
			5	6.5 [.735]	SCFM	700	638	583	-	-
					RPM	1288	1348	1423	-	-
					Watts	119.8	125.5	130.3	-	-
2412SP	2 Ton	6x8 1/3HP [249] 5 Speed	1	3.1 [.350]	SCFM	400	316	237	-	-
					RPM	937	1061	1154	-	-
					Watts	45.3	50.8	55.6	-	-
			2	5.2 [.588]	SCFM	600	531	472	-	-
					RPM	1161	1240	1312	-	-
					Watts	88.9	93.8	99	-	-
			3	6 [.678]	SCFM	650	597.8	542	-	-
					RPM	1250	1306	1380	-	-
					Watts	109.2	112.3	118.2	-	-
			4	6.5 [.735]	SCFM	700	638	583	-	-
					RPM	1288	1348	1423	-	-
					Watts	119.8	125.5	130.3	-	-
			5	8.0 [.904]	SCFM	783	728	676	-	-
					RPM	1406	1466	1521	-	-
					Watts	162.6	166.8	175.7	-	-
3012SP	2.5 Ton	7x8 1/2HP [373] 5 Speed	1	7.8 [.881]	SCFM	765	700	641	-	-
					RPM	1110	1188	1252	-	-
					Watts	126.2	134.9	139.9	-	-
			2	11.0 [1.243]	SCFM	958	900	837	-	-
					RPM	1300	1386	1412	-	-
					Watts	203.1	209.2	217.5	-	-
			3	12.3 [1.389]	SCFM	1021	960	907	-	-
					RPM	1358	1413	1468	-	-
					Watts	233.4	242.5	250.6	-	-
			4	13.5 [1.526]	SCFM	1077	1020	961	-	-
					RPM	1412	1464	1522	-	-
					Watts	265.1	273.6	283.8	-	-
			5	15.0 [1.694]	SCFM	1174.8	1132.4	1088.9	1049.5	1007.1
					RPM	1412	1468	1520	1561	1615
					Watts	302.4	313.3	320.1	329.9	336.2
3612SP	3 Ton	7x8 1/2HP [373] 5 Speed	1	7.8 [.881]	SCFM	765	700	641	573	520
					RPM	1110	1188	1252	1332	1402
					Watts	126.2	134.9	139.9	147.1	154.4
			2	11.0 [1.243]	SCFM	958	900	837	786	732
					RPM	1300	1386	1412	1468	1531
					Watts	203.1	209.2	217.5	225.7	232.8
			3	12.3 [1.389]	SCFM	1021	960	907	851	798
					RPM	1358	1413	1468	1526	1575
					Watts	233.4	242.5	250.6	258.9	266.7
			4	13.5 [1.526]	SCFM	1077	1020	961	911	862
					RPM	1412	1464	1522	1568	1626
					Watts	265.1	273.6	283.8	289.1	298.9
			5	15.0 [1.694]	SCFM	1174.8	1132.4	1088.9	1049.5	1007.1
					RPM	1412	1468	1520	1561	1615
					Watts	302.4	313.3	320.1	329.9	336.2

Notes: Constant Torque motor speed changes.

- All Constant Torque motors have 5 speed tabs. Speed tab 2,3 & 4 will be wired from the factory. Tab 1 should be used for extremely low static applications and Tab 5 should be used for extremely high static applications (refer to airflow performance data for correct usage)

[ ] Designates Metric Conversions



# AIRFLOW PERFORMANCE

## 5.2 AIRFLOW PERFORMANCE DATA - EL3T (50HZ WITH CONSTANT TORQUE MOTOR) - continued

Model No. EL3T	Tonnage Application	Blower Size/ Motor HP [W] # of Speeds	Speed Tap	Torque Value lb*in [N*m]		CFM [L/s] Air Delivery/RPM/Watts -- 220-230 Volts						
						External Static Pressure -- Inches W.C. [kPa]						
						0.2 [.05]	0.3 [.07]	0.4 [.10]	0.5 [.12]	0.6 [.15]	0.7 [.17]	0.8 [.19]
4217ST	3.5 Ton	10x10 3/4HP [559] 5 Speed	1	9.1	SCFM	850	776	700	621	554	487	415
					RPM	840	880	925	964	1010	1060	1095
					Watts	136.5	143	150	156	162	168	174
			2	11.1	SCFM	1000	928	857	783	713	648	584
					RPM	901	936	975	1013	1050	1088	1130
					Watts	178	185	192	198	205	211	218
			3	13	SCFM	1130	1054	984	918	846	779	718
					RPM	953	990	1023	1060	1094	1130	1160
					Watts	221	227	234	242	247	255	260
			4	15.4	SCFM	1280	1208	1130	1067	1002	940	874
					RPM	1011	1042	1070	1100	1135	1168	1210
					Watts	273	280	287	294	303	310	321
			5	17.9	SCFM	1420	1352	1281	1208	1148	1090	1030
					RPM	1073	1100	1130	1153	1182	1211	1243
					Watts	336	344	351	358	366	374	382
4817ST	4 Ton	10x10 3/4HP [559] 5 Speed	1	14.9	SCFM	1045	897	776	672	573	481	400
					RPM	763	820	882	938	985	1044	1110
					Watts	127	136	138	145	156	165	171
			2	17.9	SCFM	1200	1107	960	845	746	650	570
					RPM	807	856	920	970	1016	1066	1120
					Watts	160	168	174	186	192	197	209
			3	20	SCFM	1300	1212	1070	966	860	767	680
					RPM	840	886	940	992	1045	1088	1133
					Watts	184	193	205	215	220	230	239
			4	23.5	SCFM	1450	1370	1286	1142	1047	950	863
					RPM	890	930	976	1028	1076	1120	1167
					Watts	228	240	250	263	273	280	290
			5	27.9	SCFM	1609	1535	1463	1385	1243	1155	1062
					RPM	950	990	1030	1068	1122	1163	1203
					Watts	291	300	312	325	333	347	355
6017ST	5 Ton	10x10 1HP [746] 5 Speed	1	18.8	SCFM	1411	1349	1262	1171	1106	1047	989
					RPM	951	988	1078	1108	1129	1172	1211
					Watts	350	365	390	400	406	425	446
			2	22.5	SCFM	1593	1537	1473	1372	1298	1240	1179
					RPM	1104	1041	1082	1130	1176	1210	1244
					Watts	440	453	467	486	503	514	526
			3	26.3	SCFM	1750	1690	1630	1568	1454	1390	1324
					RPM	1067	1097	1130	1183	1238	1262	1286
					Watts	542	555	570	592	609	619	634
			4	30	SCFM	1873	1815	1774	1724	1659	1556	1456
					RPM	1132	1151	1180	1212	1250	1310	1357
					Watts	650	659	675	685	703	736	757
			5	33.8	SCFM	2015	1952	1900	1856	1807	1742	1650
					RPM	1180	1207	1229	1262	1287	1330	1375
					Watts	756	770	780	796	814	838	862
6518ST	5.5 Ton	10x10 1HP [746] 5 Speed	1	20.3	SCFM	1614	1563	1515	1462	1407	1358	1312
					RPM	951	917	956	983	1020	1053	1088
					Watts	250	210	237	266	294	321	349
			2	27.5	SCFM	1862	1804	1748	1687	1623	1567	1514
					RPM	1004	997	1033	1058	1092	1123	1155
					Watts	391	373	395	419	440	462	486
			3	31.1	SCFM	1986	1924	1864	1799	1731	1671	1614
					RPM	1031	1037	1072	1096	1128	1158	1189
					Watts	462	454	474	495	514	533	555
			4	38.3	SCFM	2235	2165	2097	2024	1948	1880	1816
					RPM	1084	1118	1150	1171	1200	1228	1256
					Watts	603	618	632	647	660	675	691
			5	45	SCFM	2483	2405	2330	2249	2164	2089	2018
					RPM	1133	1160	1186	1211	1242	1271	1304
					Watts	736	751	763	775	790	802	819

**NOTE:**

All constant torque air handlers are shipped from the factory at speed taps 2, 3, & 4. Tap 1 should be used for extremely low static applications (0.1 inches W.C. or less). Tap 5 should be used for high static applications or to achieve rated capacity.



## Sound Pressure Values - EL3T (Constant Torque (ECM) Motor)

Model	Blower Speed	Indoor Airflow (SCFM)	External Static Pressure (InWC)	Sound Pressure (dbA)
EL3T1812SPBCTA	Low	350	0.1	31.5*
	Med. Low	450	0.1	36.5*
	Medium	490	0.1	37.5*
	Med. High	525	0.1	39.5*
	High (Rated)	700	0.1	45.5*
EL3T2412SPBCTA	Low	400	0.1	34.5*
	Med. Low	600	0.1	42.5*
	Medium	650	0.1	43.5*
	Med. High	700	0.1	45.5*
	High (Rated)	783	0.1	47.5*
EL3T3012SPBCTA	Low	765	0.1	35.5*
	Med. Low	958	0.1	40.5*
	Medium	1021	0.1	41.5*
	Med. High	1077	0.1	42.5*
	High (Rated)	1175	0.1	42.5*
EL3T3612SPBCTA	Low	765	0.1	35.5*
	Med. Low	958	0.1	40.5*
	Medium	1021	0.1	41.5*
	Med. High	1077	0.1	42.5*
	High (Rated)	1175	0.1	42.5*
EL3T4217STACTA	Low	700	0.2	32.5*
	Med. Low	800	0.2	34.5*
	Medium	930	0.2	36.5*
	Med. High	1050	0.2	39.5*
	High (Rated)	1163	0.2	41.5*
EL3T4817STACTA	Low	1045	0.2	35.5*
	Med. Low	1200	0.2	37.5*
	Medium	1300	0.2	38.5*
	Med. High	1450	0.2	40.5*
	High (Rated)	1609	0.2	42.5*
EL3T6017STACTA	Low	1411	0.2	42.0*
	Med. Low	1593	0.2	44.0*
	Medium	1750	0.2	46.0*
	Med. High	1873	0.2	48.0*
	High (Rated)	2015	0.2	50.0*
EL3T6518STACTA	Low	1614	0.2	43.7*
	Med. Low	1862	0.2	44.5*
	Medium	1986	0.2	45.1*
	Med. High	2234	0.2	45.6*
	High (Rated)	2483	0.2	46.2*

\*sound pressure levels are calculated from sound power level data.

### Sound Testing Arrangement

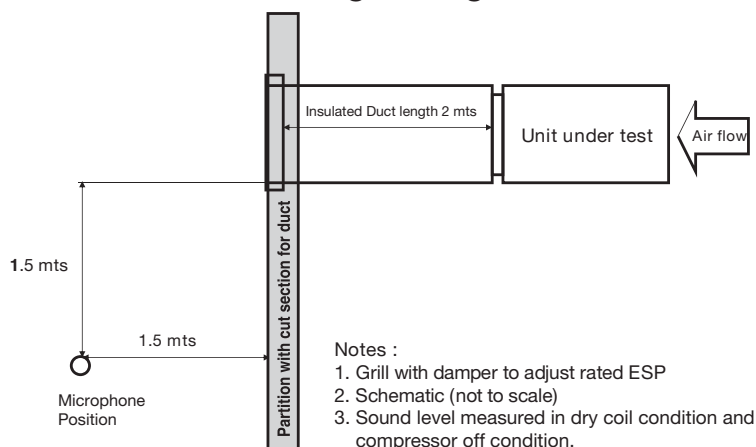

## ELECTRICAL DATA - BLOWER MOTOR ONLY NO ELECTRIC HEAT EL3T

Model EL3T	Voltage	Application Phase	Frequency (Hz)	HP [W]	Speeds	Circuit Amps	Minimum Circuit Ampacity	Maximum Circuit Protector
EL3T1812SPACTA	220-240	1	50	1/3 [249]	5	3.0	4	15
EL3T2412SPACTA				1/3 [249]		3.0	4	15
EL3T3012SPACTA				1/2 [373]		4.1	6	15
EL3T3612SPACTA				1/2 [373]		4.1	6	15
EL3T4217STACTA				1/2 [373]		4.1	6	15
EL3T4817STACTA				3/4 [559]		5.7	6	15
EL3T6017STACTA				1 [746]		7.0	8	15
EL3T6518STACTA				1 [746]		7.0	8	15

### Electrical Wiring

#### Power Wiring

- Field wiring must comply with the National Electrical Code and any applicable local ordinance.
- Supply wiring must be suitable for 75°C minimum and with copper conductors only
- See electrical data for product Ampacity rating and Circuit Protector requirement.

#### Grounding

- This product must be sufficiently grounded in accordance with National Electrical Code and any applicable local ordinance.
- A grounding lug is provided.



# SAGN UNIT DIMENSIONS

Figure	Model No. SAGN	Unit Dimensions		
		Height "H" in. [mm]	Length "L" in. [mm]	Width "W" in. [mm]
FIG. 1	18, 24	24 1/4 [616]	23 5/8 [600]	23 5/8 [600]
FIG. 2	30, 36, 42, 48, 60, 65	35 3/8 [913]	31 5/8 [803]	31 5/8 [803]

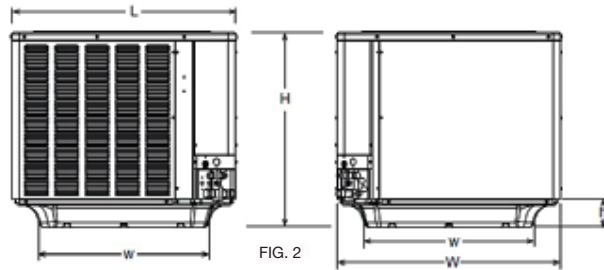
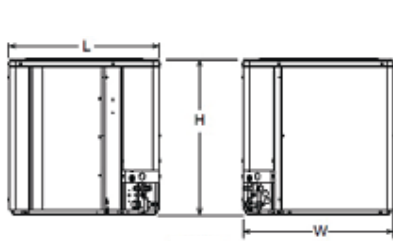
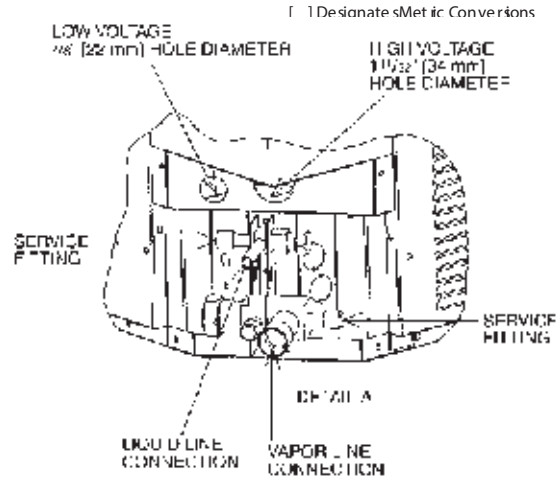
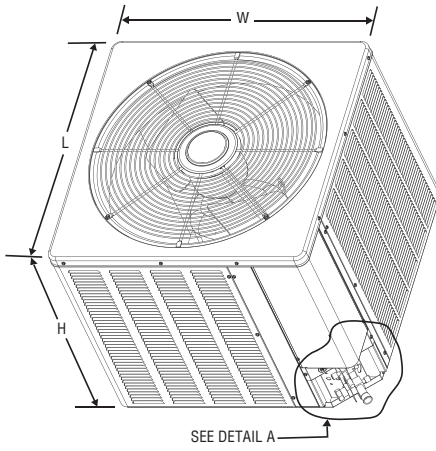

## ELECTRICAL AND PHYSICAL DATA

Model Number	Electrical						Physical						
	Phase Frequency (Hz) Voltage (Volts)	Compressor		Fan Motor Full Load Amperes (FLA)	Minimum Circuit Ampacity Amperes	Fuse or HACR Circuit Breaker		Outdoor Coil			Refrigerant Included Oz. [kg]	Weight	
		Rated Load Amperes (RLA)	Locked Rotor Amperes (LRA)			Minimum Amperes	Maximum Amperes	Face Area Sq. Ft. [m <sup>2</sup> ]	No. Rows	CFM [L/s]		Net Lbs. [kg]	Shipping Lbs. [kg]
*AGN-018**	1-50-220-240	10/10	52	0.5	12/12	15/15	20/20	8.43 [0.78]	1	1600 [755]	69 [1.956]	121 [54.9]	129 [58.5]
*AGN-024**	1-50-220-240	10.9/10.9	60	0.5	15/15	20/20	25/25	8.43 [0.78]	1	1600 [755]	82.9 [2.350]	121 [54.9]	129 [58.5]
*AGN-030**	1-50-220-240	15/15	67	0.68	18/18	25/25	30/30	19.28 [1.79]	1	2517 [1188]	124.8 [3.538]	223 [101.2]	234 [106.1]
*AGN-036**	1-50-220-240	17.9/17.9	87	2.8	23/23	30/30	35/35	21.85 [2.03]	1	3666 [1730]	176 [4.989]	205 [93]	225 [102.1]
*AGN-042N**	3-50-380-415	6.9/6.9	41	0.9	9/9	15/15	15/15	21.85 [2.03]	1	3295 [1555]	125 [3.544]	222 [100.7]	233 [105.7]
*AGN-048N**	3-50-380-415	7.1/7.1	55	1.0	9/9	15/15	15/15	21.85 [2.03]	1	3550 [1675]	129 [3.657]	205 [93]	225 [102.1]
*AGN-060N**	3-50-380-415	8.7/8.7	66.1	1.0	12/12	15/15	20/20	21.85 [2.03]	2	4310 [2034]	243 [6.889]	249 [112.9]	269 [122.1]
*AGN-065N**	3-50-380-415	10.9/10.9	64	1.5	14/14	20/20	20/20	21.85 [2.03]	2	4310 [2034]	243 [6.889]	249 [112.9]	269 [122.1]

NOTE: Factory Refrigerant Charge includes refrigerant for 15 feet of standard line set.

[ ] Designates Metric Conversions





# EL3T UNIT DIMENSIONS

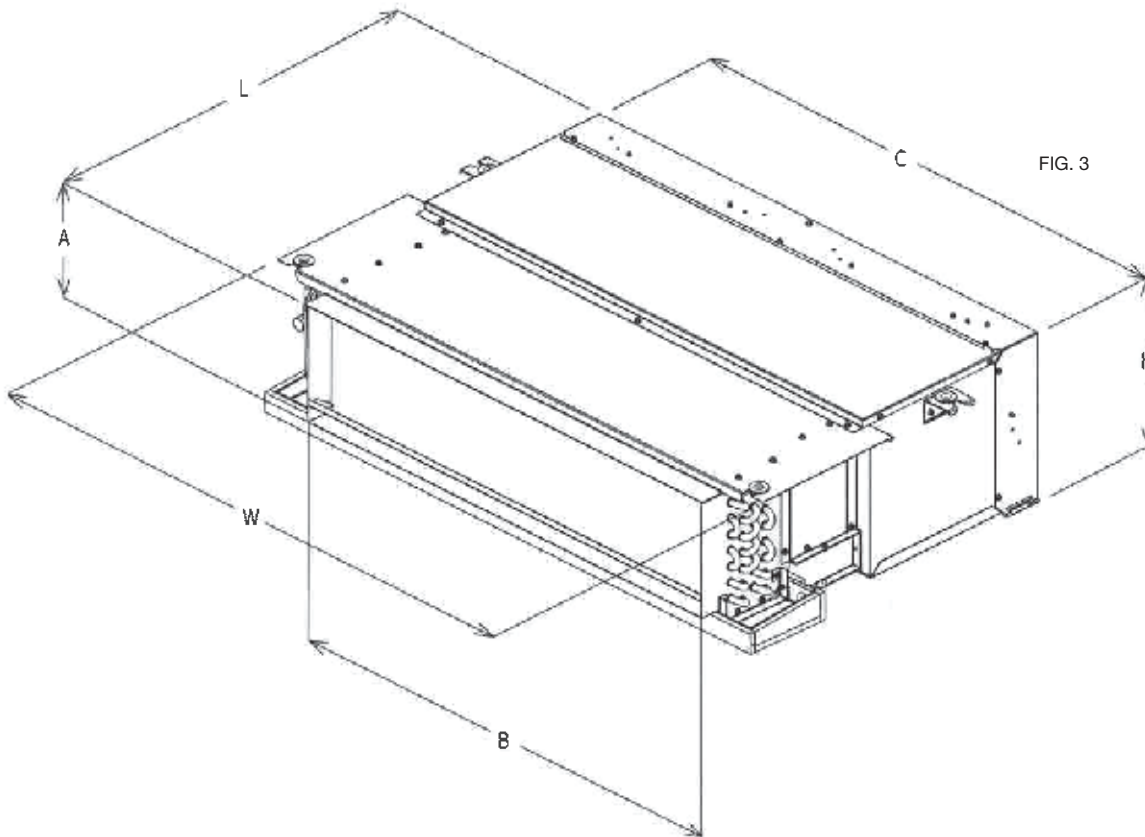

## UNIT DIMENSIONS & WEIGHTS

MODEL EL3T	REFRIGERANT CONNECTIONS		UNIT HEIGHT "H" IN. [MM]	UNIT WIDTH "W" IN. [MM]	UNIT LENGTH "L" IN. [MM]	SUPPLY DUCT		RETURN DUCT	UNIT WEIGHT / SHIPPING WEIGHT LBS. [KG]
	SWEAT ID (IN) [MM]					A	B	C	
	LIQUID	VAPOR							
1812SPBCTA	3/8 [9.53]	3/4 [19.05]	10.5 [264.54]	37 [939.80]	24.4 [619.76]	7.25 [183.90]	30 [763.73]	33.5 [850.95]	78/84.62 [35.38/38.38]
2412SPBCTA	3/8 [9.53]	3/4 [19.05]	10.5 [264.54]	37 [939.80]	24.4 [619.76]	7.25 [183.90]	30 [763.73]	33.5 [850.95]	78/84.62 [35.38/38.38]
3012SPBCTA	3/8 [9.53]	3/4 [19.05]	10.5 [264.54]	49 [1244.60]	25.3 [642.62]	7.25 [183.90]	42 [1066.80]	45.5 [1155.70]	98/104.60 [44.45/47.45]
3612SPBCTA	3/8 [9.53]	3/4 [19.05]	10.5 [264.54]	49 [1244.60]	25.3 [642.62]	7.25 [183.90]	42 [1066.80]	45.5 [1155.70]	98/104.60 [44.45/47.45]
4217STACTA	3/8 [9.53]	3/4 [19.05]	16.07 [408.2]	47.1 [1196]	29.43 [747]	11.65 [296]	37.63 [956]	32.56 [827]	126.5/153.0 [57.38/69.40]
4817STACTA	3/8 [9.53]	3/4 [19.05]	16.07 [408.2]	60.2 [1530]	29.43 [747]	11.69 [297]	50.69 [1287]	34.09 [866]	147.5/155.0 [66.9/70.3]
6017STACTA	3/8 [9.53]	3/4 [19.05]	16.07 [408.2]	60.2 [1530]	29.43 [747]	11.69 [297]	50.69 [1287]	34.09 [866]	147.5/155.0 [66.9/70.3]
6518STACTA	3/8 [9.53]	3/4 [19.05]	16.57 [420.9]	61.6 [1564]	29.43 [747]	12.99 [330]	52.38 [1330]	34.09 [866]	176.5/184.5 [80/83.6]

**Notes:**

Units 1.5 - 3.0TR are blow-through

Units 3.5 - 5.5TR are draw-through



## AIRFLOW DIRECTIONAL DATA Blow-through - (1.5TR - 3.0TR)

HORIZONTAL RETURN

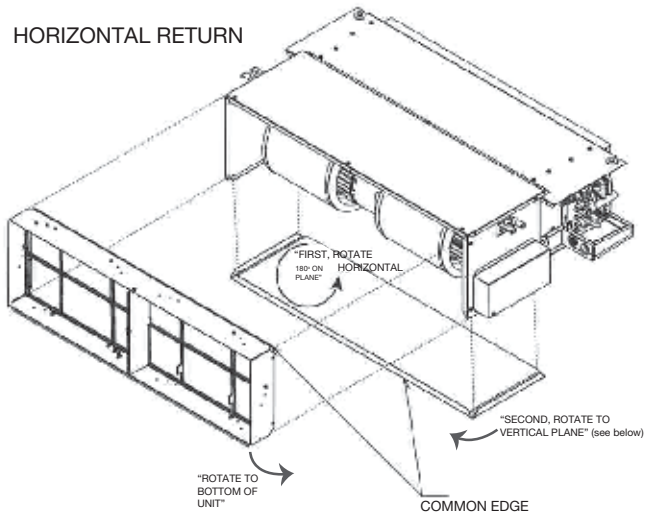
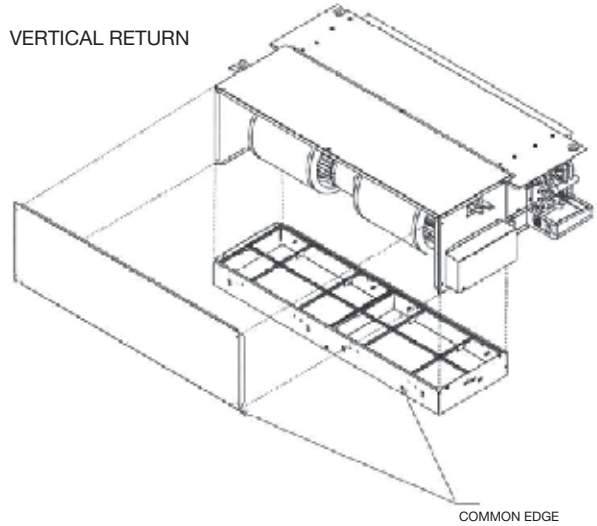
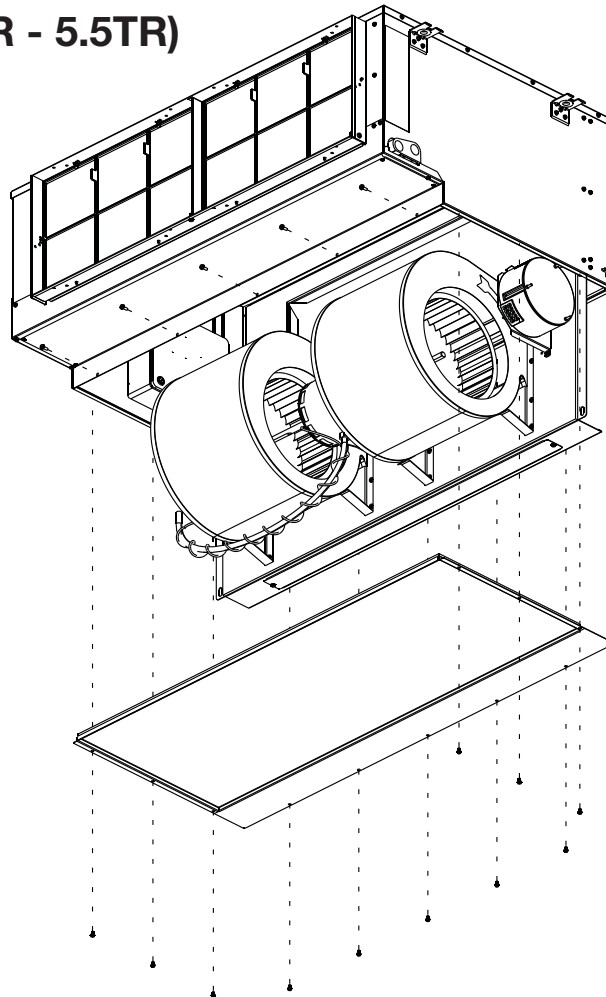

FIG. 5

VERTICAL RETURN



## AIRFLOW DIRECTIONAL DATA Draw-through (3.5TR - 5.5TR)



## Selecting and Sizing Line Sets [SAGN Models]

### Line Sets and Fitting Losses

Refrigerant lines are measured in terms of actual length and equivalent length. Actual length is used for refrigerant charge applications and is the measurement of all of the vertical and horizontal lines from the indoor and outdoor units. Equivalent length takes into account pressure losses from line lengths, fittings, vertical separations, accessories, and filter dryers. Table 1 below provides equivalent lengths for different commonly used parts in refrigerant lines. Equivalent length is the sum of the actual length of the line set plus the equivalent length of all fittings, accessories, and filter dryers. Equivalent length is used in determining proper line sizing and installation.

**Table 1**

Equivalent Length for Fittings (ft)							
Line Size (in)	90° Short Radius Elbow	90° Long Radius Elbow	45° Elbow	Solenoid Value	Check Valve	Site Glass	Filter Dryer
3/8	1.3	0.8	0.3	6	4	0.4	6
1/2	1.4	0.9	0.4	9	5	0.6	6
5/8	1.5	1	0.5	12	6	0.8	6
3/4	1.9	1.3	0.6	14	7	0.9	6
7/8	2.3	1.5	0.7	15	8	1	6
1-1/8	2.7	1.8	0.9	22	12	1.5	6

### Liquid Line Selection

The purpose of the liquid line is to transport warm sub-cooled liquid refrigerant from the outdoor unit to the indoor unit. It is important to maintain a column of liquid all the way to the expansion device and not to allow the refrigerant to flash into superheated vapor. The flashing of refrigerant can occur for the following reasons:

- Low refrigerant charge
- Improperly selected liquid line size
- Absorption of heat prior to expansion device
- Excessive vertical rise between the condenser and evaporator

The procedure for selecting the proper liquid line size and length is as follows:

- Measure the total amount of vertical rise (elevation).
- Measure the actual amount of liquid line required.
- Add all of the equivalent lengths associated with any fittings or accessories using Table 1.
- Add the actual length and equivalent lengths. This will equal your total equivalent length.
- Reference the Line Sizing Chart that matches the application (e.g. ODU above, ODU below, ODU same elevation as the IDU3) and the capacity size of the equipment.
- Verify that the value of the calculated total equivalent length is compatible with the applications vertical rise and diameter of the liquid line.
- Using the equivalent length total and the vertical rise in the application (if required) to determine the size and allowable lengths of the liquid line piping.

#### Liquid Line General Notes:

- Regardless of equivalent length, the actual linear length of the tubing shall not exceed 200'.
- Design of the liquid line must not exceed 400 FPM and must have a minimum of 100 FPM.
- Liquid lines must be sized to minimize refrigerant pressure change.
- Sufficient refrigerant sub-cooling must be maintained at the expansion device for proper system operation.
- R-410A loses 0.43 PSI for every foot of vertical lift as a liquid. Length of pipe, fittings, liquid line filter drier also add pressure drop thus limiting applications where the outdoor unit is below the indoor unit to much shorter distances than when the outdoor unit is above the indoor unit.
- When the outdoor unit is above the indoor unit, the vertical line experiences an increase in PSIG (Static Gain) which will also lead to changes in subcooling at the metering device.
- The total pressure drop allowed for the liquid line is 50 PSI.

## Vapor Suction Line Selection

The purpose of the suction line is to return superheated vapor to the compressor from the evaporator. Suction line sizing and refrigerant velocity is important as they have a role in ensuring the return of oil to the compressor. An improperly sized suction line can reduce performance of the system.

The procedure for selecting the proper liquid line size is as follows:

Measure the total amount of vertical rise (elevation).

- Measure the actual amount of suction line required.
- Add all of the equivalent lengths associated with any fittings or accessories using Table 1.
- Add the actual length and equivalent lengths. This will equal your total equivalent length of suction line.
- Reference the Line Sizing Charts that matches the application (e.g. ODU above, below, or same elevation as the IDU) and the capacity size of the equipment.
- Verify that the value of the calculated total equivalent length is compatible with the applications vertical rise and diameter of the liquid line.
- Using the equivalent length total and the vertical rise in the application (if required) to determine the size and allowable lengths of the liquid line piping.

### Suction Line General Notes:

- The Manufacturer does NOT require traps in the suction line when the condenser is above the evaporator, and recommends they not be used. The combination of miscibility of the POE oil and R-410A, along with compliance to the refrigerant line design instructions will ensure oil is properly returned without exceeding pressure drop limits in the vapor line. Traps will add to the pressure drop and therefore are counterproductive when the suction line is sized according to these guidelines.
- Refrigerant velocity for vertical suction risers must be maintained at 1100 FPM to ensure oil return. Horizontal suction lines must maintain 800 FPM. This will often result in different size refrigerant lines between horizontal and vertical applications. While gravity has very little effect on the gas itself, oil and pressure drop are still key factors.
- It is acceptable to use the larger size suction line for shorter horizontal runs and in applications where the indoor unit is above the outdoor unit to prevent capacity losses.
- Pressure drop within the suction line should be limited to 5 psi for R410A systems although the longest lines may slightly exceed this limit in an effort to maintain velocity. The maximum pressure is 7 psi.
- Suction line pressure loss reduces capacity by 0.6% for R-410A per psi. In order to minimize capacity loss suction pressure loss must be minimized.

## Refrigerant Level Adjustment

The residential outdoor units (ODU) are R-410A factory charged. The factory charge amount accounts for the ODU volume and an additional 15 feet of refrigerant tubing with a liquid line diameter of 3/8". This factory charge does not account for the volume of the factory supplied, field installed liquid line filter drier. Final adjustment of the refrigerant charge may be necessary during the system commissioning even if the application has exactly 15 feet of line set due to other installation variables such as the filter drier and pressure drops due to vertical separation. If additional refrigerant charge is needed it should be added before opening the ODU valves.

Adjust the refrigerant charge by using the actual liquid line length and the table below that indicates refrigerant charge in ounces per foot of the indicated liquid line size:

- 1/4" line diameter uses 0.3 ounces per foot of line (6.4 mm uses 8.5g per .30 m)
  - 5/16" line diameter uses 0.4 ounces per foot of line (7.9mm uses 11.3g per .30m)
  - 3/8" line diameter uses 0.6 ounces per foot of line (9.5mm uses 17.0g per .30 m)
  - 1/2" line diameter uses 1.2 ounces per foot of line (12.7mm uses 34.0g per .30 m)
  - Note: The factory provided filter drier requires an additional 6.0 ounces of refrigerant.
  - Note: The factory provided charge to account for the 15 feet of line set is 9 oz. (based on 3/8" line, 0.6 oz. per foot)
- Charge Adjustment = (Line Diameter oz. per ft.) x Total Actual Length) – Factory Charge + Filter Drier

## Additional Oil Adjustment

All refrigerant in the system will carry a small amount of oil. As more refrigerant is added to the system, additional oil will also need to be added.

The formula for determining how much oil to add to the system is as follows:

Oil to be Added = [(Charge Adjustment + OD Unit Name Plate Charge (oz.)) x (0.022) – [(0.10) x (Compressor Name Plate Oil Charge (oz.))]

## OUTDOOR UNIT ABOVE THE INDOOR UNIT

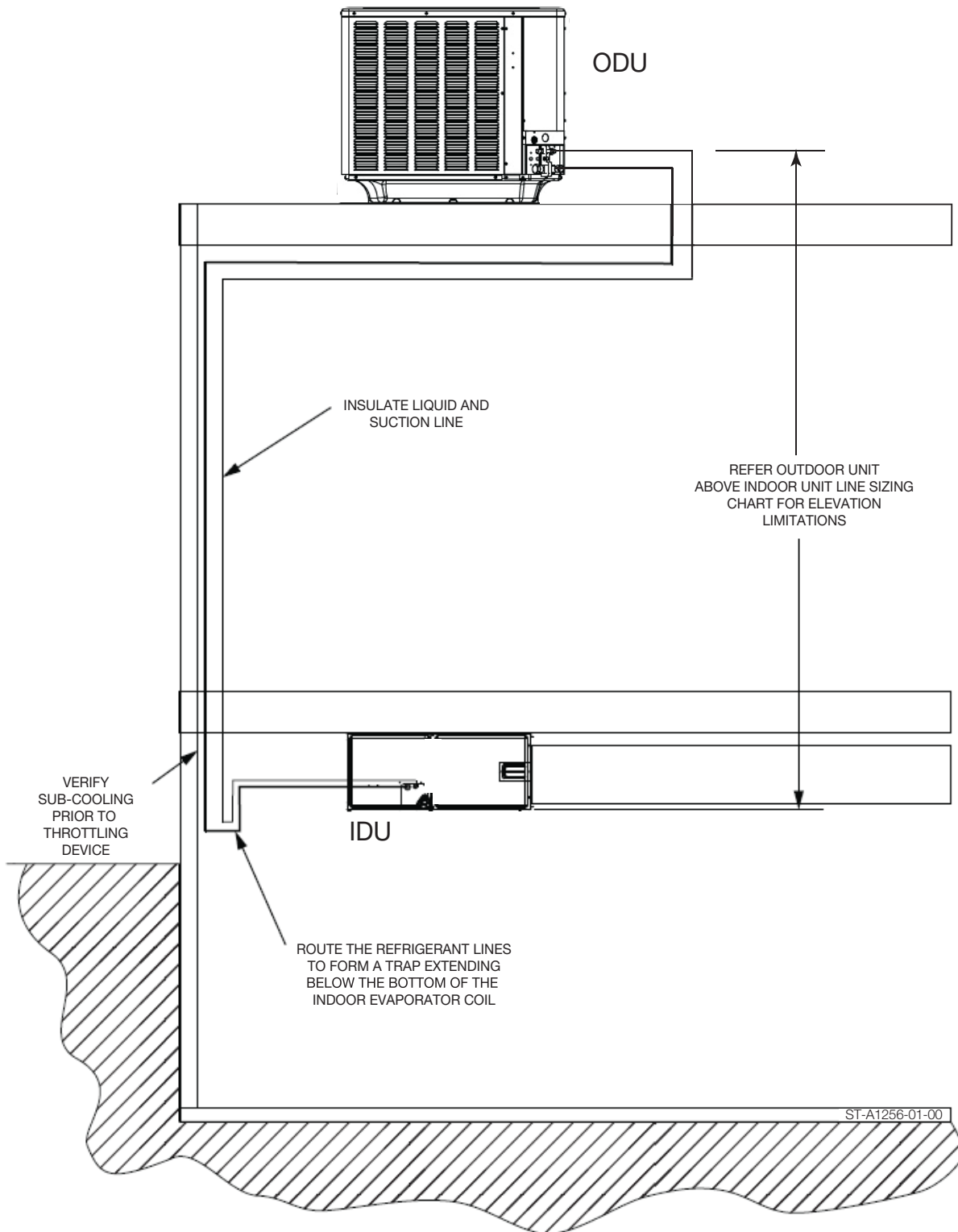

Note: Following is the chart specific to applications where the outdoor unit is above the indoor coil. Do not confuse charts designated with outdoor unit above indoor coil, with charts designated with outdoor unit below indoor coil.

# PIPE SIZE CHART

Outdoor Unit ABOVE Indoor Unit																	
Single Stage	Liquid Line Size	Suction Line size	Equivalent Length in Meters														
			Condition - A					Condition - B					Condition - C				
			15.5-22.5	23-45	38-45	45-75	75-90	45.5-52.5	53-60	61.5-67.5	68-75	75.5-82.5	83-90				
Maximum Vertical Separation / Capacity Multiplier																	
SAGN-018	1/4"	5/8"	15/1.00	22.5/0.99	33.5/0.99	40/0.98	N/A	N/A	52.5/0.97	N/A	N/A	N/A	N/A	N/A	N/A	N/A	
	5/16"	5/8"	15/1.00	22.5/0.99	33.5/0.98	40/0.98	45/0.96	45/0.95	52.5/0.97	58/0.97	60/0.96	60/0.96	55/0.96	52.5/0.96	60/0.96	60/0.95	
	3/8"	5/8"	15/1.00	22.5/0.99	33.5/0.98	40/0.98	45/0.96	45/0.95	52.5/0.97	60/0.97	60/0.96	60/0.96	60/0.96	60/0.96	60/0.96	60/0.95	
SAGN-024	1/4"	5/8"	15/1.00	22.5/0.99	33.5/0.98	N/A	N/A	N/A	N/A	N/A	N/A	N/A	N/A	N/A	N/A	N/A	
	5/16"	5/8"	15/1.00	22.5/0.99	33.5/0.98	40/0.97	45/0.95	N/A	52/0.97	55/0.96	60/0.96	60/0.95	47/0.95	N/A	N/A	N/A	
	3/8"	5/8"	15/1.00	22.5/0.99	33.5/0.98	40/0.97	45/0.95	45/0.94	52.5/0.97	60/0.96	60/0.96	60/0.95	60/0.95	60/0.95	60/0.95	60*/0.94	
SAGN-030	5/16"	5/8"	15/0.98	22.5/0.97	33.5/0.97	40/0.95	N/A	N/A	N/A	N/A	N/A	N/A	N/A	N/A	N/A	N/A	
	3/8"	5/8"	15/0.98	22.5/0.97	33.5/0.97	40/0.95	45/0.92	45/0.91	52.5/0.94	60/0.93	60/0.93	60/0.93	60/0.92	60*/0.92	60*/0.92	60*/0.91	
	5/16"	3/4"	15/1.00	22.5/0.99	33.5/0.99	40/0.98	N/A	N/A	N/A	N/A	N/A	N/A	N/A	N/A	N/A	N/A	
SAGN-036	3/8"	3/4"	15/1.00	22.5/0.99	33.5/0.99	40/0.98	45/0.97	45/0.96	52.5/0.98	60/0.98	60/0.97	60/0.97	60*/0.97	60*/0.97	60*/0.97	60*/0.96	
	5/16"	5/8"	15/0.98	22.5/0.97	33.5/0.96	40/0.93	N/A	N/A	N/A	N/A	N/A	N/A	N/A	N/A	N/A	N/A	
	3/8"	5/8"	15/0.98	22.5/0.97	33.5/0.96	40/0.93	45/0.90	45/0.88	52.5/0.93	60/0.91	60/0.90	60/0.90	60*/0.89	60*/0.89	60*/0.89	60*/0.88	
SAGN-042	5/16"	3/4"	15/1.00	22.5/1.00	33.5/0.99	40/0.97	45/0.97	45/0.96	52.5/0.96	60/0.98	60/0.98	60/0.97	60/0.97	60*/0.96	60*/0.96	60*/0.95	
	3/8"	3/4"	15/1.00	22.5/0.99	33.5/0.99	N/A	N/A	N/A	N/A	N/A	N/A	N/A	N/A	N/A	N/A	N/A	
	5/16"	7/8"	15/1.00	22.5/1.00	33.5/1.00	N/A	N/A	N/A	N/A	N/A	N/A	N/A	N/A	N/A	N/A	N/A	
SAGN-048	3/8"	3/4"	15/0.98	22.5/0.97	33.5/0.96	40/0.95	45/0.92	45/0.91	52.5/0.94	60/0.93	60/0.93	60/0.92	58*/0.92	52*/0.92	47*/0.91	60*/0.91	
	1/2"	3/4"	15/0.98	22.5/0.97	33.5/0.96	40/0.95	45/0.92	45/0.91	52.5/0.94	60/0.93	60/0.93	60/0.92	60/0.92	60*/0.92	60*/0.91	60*/0.91	
	3/8"	7/8"	15/1.00	22.5/0.98	33.5/0.98	40/0.97	45/0.96	45/0.96	52.5/0.97	60/0.97	60/0.96	60/0.96	58*/0.96	52*/0.96	47*/0.96	60*/0.96	
SAGL-060/065	1/2"	7/8"	15/1.00	22.5/0.98	33.5/0.98	40/0.97	45/0.96	45/0.96	52.5/0.97	60/0.97	60/0.96	60/0.96	60*/0.96	60*/0.96	60*/0.96	60*/0.96	
	3/8"	3/4"	15/0.98	22.5/0.96	33.5/0.95	40/0.93	45/0.90	N/A	52.5/0.92	60*/0.92	60*/0.92	55*/0.91	49*/0.90	N/A	N/A	N/A	
	1/2"	3/4"	15/0.98	22.5/0.96	33.5/0.95	40/0.93	45/0.90	45/0.89	52.5/0.92	60/0.92	60/0.92	60/0.91	60/0.90	60*/0.90	60*/0.89	60*/0.89	
SAGL-060/065	3/8"	7/8"	15/1.00	22.5/0.99	33.5/0.98	40/0.97	45/0.95	N/A	52.5/0.97	60*/0.96	60*/0.96	55*/0.96	49*/0.95	N/A	N/A	N/A	
	1/2"	7/8"	15/1.00	22.5/0.99	33.5/0.98	40/0.97	45/0.95	45/0.94	52.5/0.97	60/0.96	60/0.96	60/0.96	60*/0.95	60*/0.95	60*/0.94	60*/0.94	

Note: This chart is applicable for ODU with scroll compressor only.

- Light Gray - (<45m vertical separation)
- Dark Gray - Use Oil Separator and Crank case heater. (Less than 45m vertical separation)
- Black - Use Oil Separator, Crank case heater, Hard Start Kit and Non-bleed TXV.
- Not Recommended
- \* Applications with asterisks (\*) require a minimum of 15m vertical separation.

Light Gray - (<45m vertical separation)  
Dark Gray  
Black

Condition	Total Equivalent Length (M)	Max. Vertical Separation (M)
A	3 ~ 45	<33.5
B	45.1 ~ 90	34 ~ 45
C	45.1 ~ 90	45.1 ~ 60

## OUTDOOR UNIT BELOW THE INDOOR UNIT

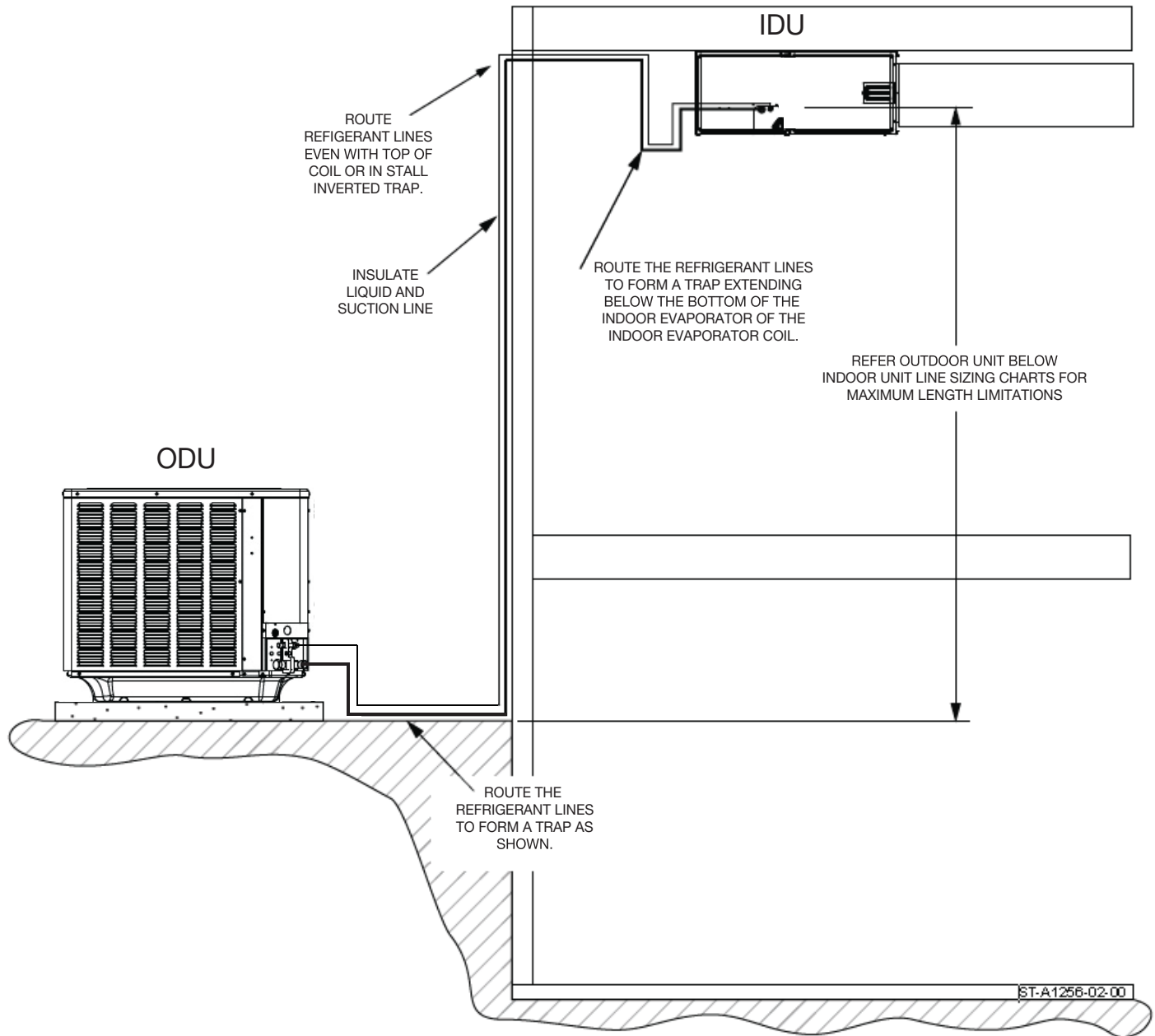

Note: Following is the chart specific to applications where the outdoor unit is below the indoor coil. Do not confuse charts designated with outdoor unit below indoor coil, with charts designated with outdoor unit above indoor coil.



# PIPE SIZE CHART

Single Stage	Liquid Line Size	Suction Line Size	Outdoor Unit BELOW Indoor Unit													
			Equivalent Length in Meter													
			<15	15.5-22.5	23-30	30.5-37.5	38 - 45	45.5-52.5	53-60	61.5-67.5	68-75	75.6-82.5	83-90			
			Maximum vertical Separation / Capacity Multiplier													
SAGN-018	5/16"	5/8"	15/0.99	21.0/0.99	18/0.98	13.5/0.98	10.5/0.98	6/0.97	3/0.97	N/A	N/A	N/A	N/A	N/A	N/A	N/A
	3/8"	5/8"	15/0.99	22.5/0.99	24.5/0.98	24.5/0.98	24.5/0.98	24.5/0.97	24.5/0.97	24.5/0.96	24.5/0.96	24.5/0.96	24.5/0.96	24.5/0.96	24.5/0.96	24.5/0.96
	5/16"	3/4"	15/1.00	21.0/1.00	18/1.00	13.5/1.00	10.5/0.99	6/0.99	3/0.99	N/A	N/A	N/A	N/A	N/A	N/A	N/A
	3/8"	3/4"	15/1.00	22.5/1.00	24.5/1.00	24.5/1.00	24.5/0.99	24.5/0.99	24.5/0.99	24.5/0.99	24.5/0.99	24.5/0.99	24.5/0.99	24.5/0.99	24.5/0.99	24.5/0.99
SAGN-024	5/16"	5/8"	15/1.00	13.5/0.99	25/0.98	N/A	N/A	N/A	N/A	N/A	N/A	N/A	N/A	N/A	N/A	N/A
	3/8"	5/8"	15/1.00	22.5/0.99	24.5/0.98	24.5/0.97	24.5/0.97	24.5/0.96	24.5/0.96	24.5/0.96	24.5/0.96	24.5/0.96	24.5/0.96	24.5/0.96	24.5/0.96	24.5/0.96
	5/16"	3/4"	15/1.00	13.5/1.00	25/1.00	N/A	N/A	N/A	N/A	N/A	N/A	N/A	N/A	N/A	N/A	N/A
	3/8"	3/4"	15/1.00	22.5/1.00	24.5/1.00	24.5/1.00	24.5/0.99	24.5/0.99	24.5/0.99	24.5/0.99	24.5/0.99	24.5/0.99	24.5/0.99	24.5/0.99	24.5/0.99	24.5/0.99
SAGN-030	5/16"	5/8"	12/09.8	3/0.97	N/A	N/A	N/A	N/A	N/A	N/A	N/A	N/A	N/A	N/A	N/A	N/A
	3/8"	5/8"	15/0.98	22.5/0.97	24.5/0.97	24.5/0.96	24.5/0.96	24.5/0.95	24.5/0.94	24.5/0.93	24.5/0.93	24.5/0.93	24.5/0.93	24.5/0.93	24.5/0.93	24.5/0.93
	5/16"	3/4"	12/1.00	3/0.99	N/A	N/A	N/A	N/A	N/A	N/A	N/A	N/A	N/A	N/A	N/A	N/A
	3/8"	3/4"	15/1.00	22.5/0.99	24.5/0.99	24.5/0.99	24.5/0.98	24.5/0.98	24.5/0.98	24.5/0.98	24.5/0.98	24.5/0.98	24.5/0.98	24.5/0.98	24.5/0.98	24.5/0.98
SAGN-036	5/16"	3/4"	10.5/1.00	10/0.99	N/A	N/A	N/A	N/A	N/A	N/A	N/A	N/A	N/A	N/A	N/A	N/A
	3/8"	3/4"	15/1.00	22.5/0.99	24.5/0.98	24.5/0.98	24.5/0.98	24.5/0.97	24.5/0.97	24.5/0.97	24.5/0.97	24.5/0.97	24.5/0.97	24.5/0.97	24.5/0.97	24.5/0.97
	1/2"	3/4"	15/1.00	22.5/0.99	24.5/0.98	24.5/0.98	24.5/0.98	24.5/0.97	24.5/0.97	24.5/0.97	24.5/0.97	24.5/0.97	24.5/0.97	24.5/0.97	24.5/0.97	24.5/0.97
	3/8"	7/8"	15/1.00	22.5/1.00	24.5/1.00	24.5/1.00	24.5/0.99	24.5/0.99	24.5/0.99	24.5/0.99	24.5/0.99	24.5/0.99	24.5/0.99	24.5/0.99	24.5/0.99	24.5/0.99
SAGN-042	1/2"	7/8"	15/1.00	22.5/1.00	24.5/1.00	24.5/1.00	24.5/0.98	24.5/0.97	24.5/0.97	24.5/0.96	24.5/0.96	24.5/0.96	24.5/0.96	24.5/0.96	24.5/0.96	24.5/0.96
	3/8"	3/4"	15/0.99	22.5/0.99	24.5/0.98	24.5/0.98	24.5/0.98	24.5/0.97	24.5/0.97	24.5/0.96	24.5/0.96	24.5/0.96	24.5/0.96	24.5/0.96	24.5/0.96	24.5/0.96
	1/2"	3/4"	15/0.99	22.5/0.99	24.5/0.98	24.5/0.98	24.5/0.98	24.5/0.97	24.5/0.97	24.5/0.96	24.5/0.96	24.5/0.96	24.5/0.96	24.5/0.96	24.5/0.96	24.5/0.96
	3/8"	7/8"	15/1.00	22.5/1.00	24.5/1.00	24.5/1.00	24.5/1.00	24.5/0.99	24.5/0.99	24.5/0.99	24.5/0.99	24.5/0.99	24.5/0.99	24.5/0.99	24.5/0.99	24.5/0.99
SAGN-048	1/2"	7/8"	15/1.00	22.5/1.00	24.5/0.98	24.5/0.98	24.5/0.98	24.5/0.97	24.5/0.97	24.5/0.96	24.5/0.96	24.5/0.96	24.5/0.96	24.5/0.96	24.5/0.96	24.5/0.96
	3/8"	7/8"	15/1.00	22.5/1.00	24.5/1.00	24.5/1.00	24.5/1.00	24.5/0.99	24.5/0.99	24.5/0.99	24.5/0.99	24.5/0.99	24.5/0.99	24.5/0.99	24.5/0.99	24.5/0.99
	1/2"	7/8"	15/1.00	22.5/1.00	24.5/1.00	24.5/1.00	24.5/1.00	24.5/0.99	24.5/0.99	24.5/0.99	24.5/0.99	24.5/0.99	24.5/0.99	24.5/0.99	24.5/0.99	24.5/0.99
	3/8"	7/8"	15/1.00	22.5/0.98	24.5/0.97	24.5/0.96	24.5/0.96	24.5/0.95	24.5/0.95	24.5/0.95	24.5/0.95	24.5/0.95	24.5/0.95	24.5/0.95	24.5/0.95	24.5/0.95
SAGL-060/065	1/2"	3/4"	15/0.98	22.5/0.98	24.5/0.97	24.5/0.96	24.5/0.96	24.5/0.95	24.5/0.95	24.5/0.95	24.5/0.95	24.5/0.95	24.5/0.95	24.5/0.95	24.5/0.95	24.5/0.95
	3/8"	3/4"	15/0.98	22.5/0.98	24.5/0.97	24.5/0.96	24.5/0.96	24.5/0.95	24.5/0.95	24.5/0.95	24.5/0.95	24.5/0.95	24.5/0.95	24.5/0.95	24.5/0.95	24.5/0.95
	1/2"	7/8"	15/1.00	22.5/1.00	24.5/1.00	24.5/1.00	24.5/1.00	24.5/0.99	24.5/0.99	24.5/0.99	24.5/0.99	24.5/0.99	24.5/0.99	24.5/0.99	24.5/0.99	24.5/0.99
	3/8"	7/8"	15/1.00	22.5/0.99	24.5/0.99	24.5/0.99	24.5/0.98	24.5/0.98	24.5/0.98	24.5/0.98	24.5/0.98	24.5/0.98	24.5/0.98	24.5/0.98	24.5/0.98	24.5/0.98

Always Use the smallest Liquid Line allowable to keep system charge to a minimum  
 Areas in light grey shade requires long line set application (Use Oil Separator, Crank case heater, Hard Start Kit and Non-bleed TXV).  
 Do not use line sets in areas shaded in Dark Grey  
 Vertical separation cannot Exceed 24.5 meter of length.

Note: This chart is applicable for ODU with scroll compressor only.



## LONG LINE SET APPLICATIONS

This section is intended for long line applications as noted in the light grey shaded areas in the Line Sizing Charts. Long line set applications require access series, unit specific requirements, and long line set installation considerations. The following are special considerations required when installing a line set that is considered to be a long line set.

- Long line Set Accessories
- Long Line Set Unit Requirements
- Long Line Installations Considerations
- Additional Refrigerant Charge
- Additional Oil Level Adjustment
- Fitting losses and maximum equivalent length considerations.
- Refrigerant Migration in the off cycle
- Oil Return to the compressor
- Capacity losses

### **Long Line Set Accessories**

#### **Crankcase Heater**

Some models come from the factory with crankcase heaters already installed. See the Crankcase Heater table to determine if the accessory needs to be ordered and field installed.

#### **Hard Start Kit (SK-A1)**

In applications with long line sets, one characteristic will be added refrigerant. Hard Start components will increase the starting torque of the compressor in order to overcome the pressure differential on the compressor. See the Hard Start Kit Accessory Part number SK-A1 to order and field install.

### **Long Line Installation Considerations**

#### **Liquid Line Sizing**

Reference the selection and Sizing Line Sets section, Liquid Lines in this guide.

- Minimize pressure change
- Ensure sub cooled liquid at the expansion device.
- Size as small as possible without exceeding the recommended maximum pressure drop

#### **Liquid Line Insulation**

When the liquid line is run through an unconditioned space for any significant length, it is subject to losing or gaining heat from the ambient air. This can cause refrigerant to flash in the liquid line prior to the expansion device.

#### **Suction Line Sizing**

Reference the Selection and Sizing Line Sets section, Suction Lines in this guide.

- Minimize pressure loss
- In applications where ODU is Above IDU maintain refrigerant gas velocity to ensure oil return.

### **Suction Line Insulation**

Insulation may be required on the vapor line if it is traveling through, at extended distances, an unconditioned space. Insulation slows the transfer of heat absorbed by the cool vapor line preventing excess superheat by the time the refrigerant gets to the compressor.

### **Inverted Trap**

When the system is installed with the outdoor unit below the indoor coil, an inverted trap, installed at the indoor coil will prevent oil and refrigerant drainage to the outdoor unit in the off cycle. An inverted trap is simply a matter of making sure the refrigerant lines exit the indoor coil and go upward to a height above the top of the coil before going back down toward the outdoor unit.

### **Refrigerant Level Adjustment**

Longline sets will require the refrigerant charge level to be adjusted. Reference the Refrigerant Level Adjustment section to determine the amount of R-410A refrigerant is required.

- Always recheck and readjust system refrigerant charge levels as needed during the final commissioning phase.

### **Additional Oil**

With long line sets as more refrigerant is added to the system, additional oil will need to be added. Reference the Additional Oil Adjustment section to determine the quantity of POE oil to add.

### **Capacity**

Use the capacity multiplier in the Line Sizing Charts to determine the impact to the system capacity based on long line set applications. Determine that the capacity meets the application requirements.

### **Summary of Important Notes:**

- The Maximum Actual Linear Length of the refrigerant lines shall not exceed 200 ft. [61 m].
- Equivalent Length shall not exceed 300 ft. [91.4 m].
- Maximum Vertical Separation may not exceed 200 ft. [61 m].
- Maximum Vertical Separation may not exceed 90% of the total actual length.
- Maximum Vertical Lift on liquid line may not exceed 80 ft. [24.5 m] (Outdoor Unit Below and all Heat Pumps).
- Follow Refrigerant Line Sizing Charts, do not exceed lengths, vertical separation, line diameters or total actual length described in these charts.
- Understand the difference between Actual and Equivalent Lengths. Refrigerant lines are measured in terms of actual length and equivalent length. Actual length is used for refrigerant charge applications. This is the actual line set distance between the indoor and outdoor units. Equivalent length takes into account pressure losses from refrigerant line lengths, fittings, vertical separation, accessories, and filter dryers. Table 1 references different commonly used equivalent lengths for fittings and parts.
- Applications in the grey shaded areas of the Line Size Charts (Long Line Set) require the use of appropriate accessories, unit requirements, and installation considerations.

- Applications in the blacked out areas on the liquid line tables exceed manufacture recommendations.
- Additional refrigerant may be required depending on the system application.
- Additional Oil will be required when the refrigerant volume is increased.
- Additional refrigerant line insulation may be required on the vapor line and/or liquid line.
- Inverted Traps are used when the indoor coil is above the outdoor coil. This prevents oil from draining out of the evaporator in the off cycle which can accumulate near the compressor.

# SAGN WIRING DIAGRAM (1.5TR - 3.0TR)

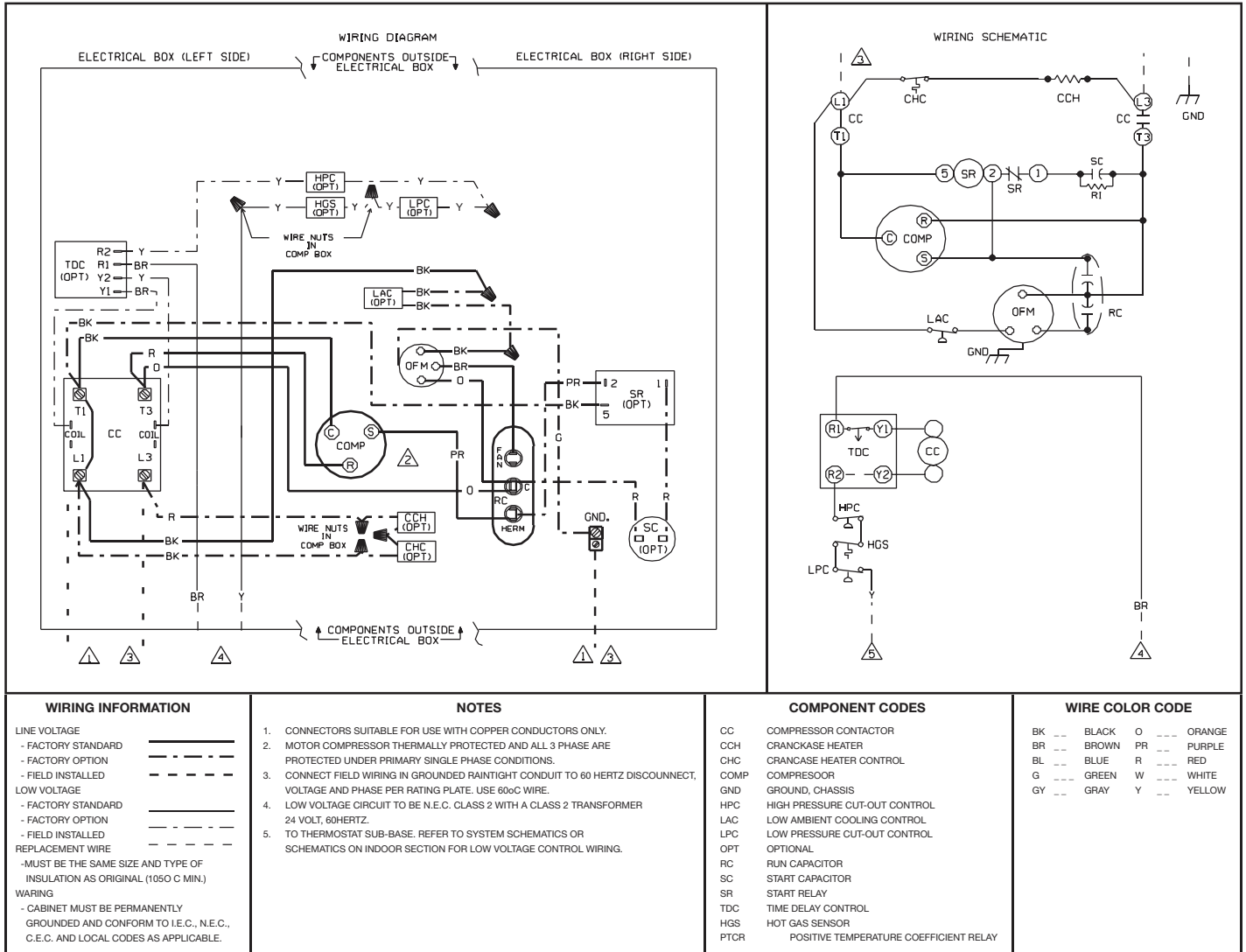

# SAGN WIRING DIAGRAM (3.5TR - 5.5TR)

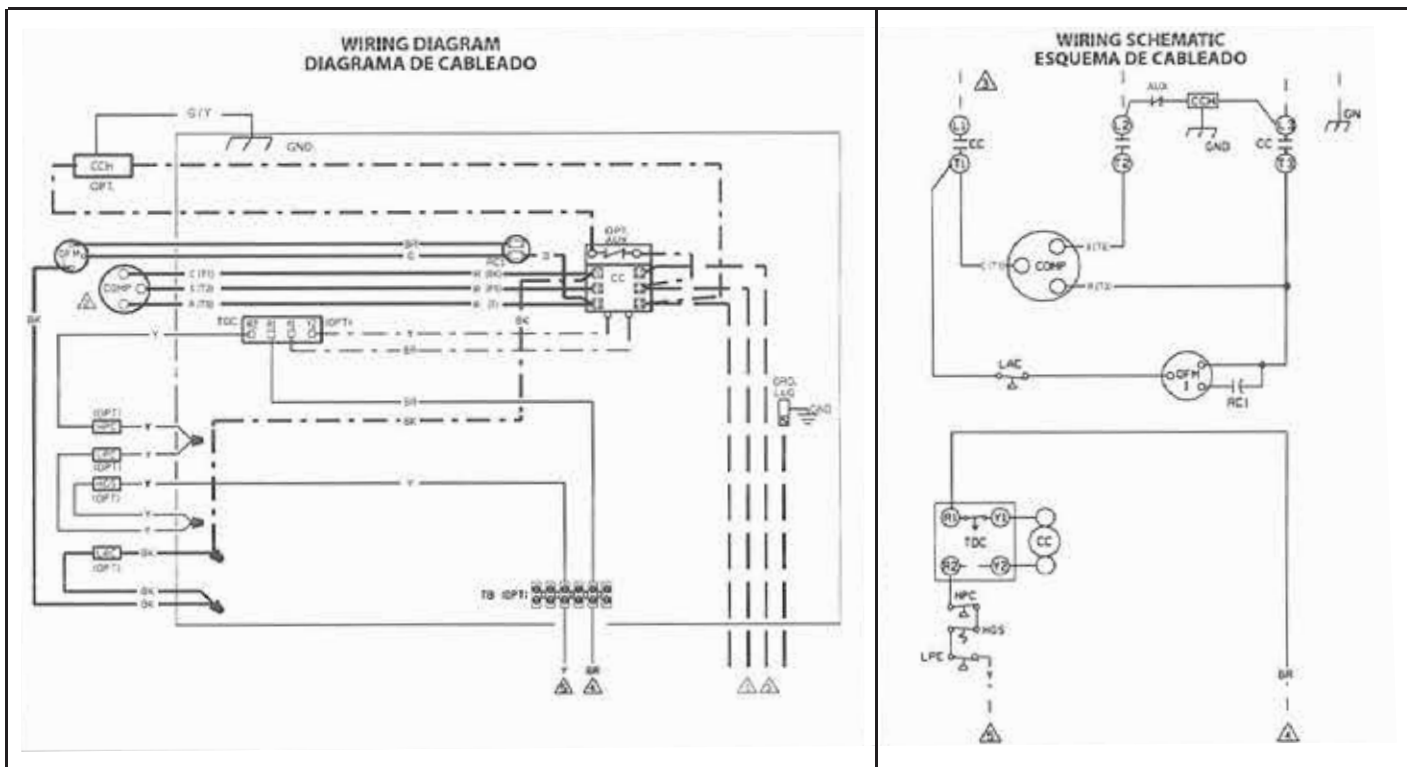

WIRING INFORMATION	NOTES	COMPONENT CODES	WIRE COLOR CODE
<p><b>LINE VOLTAGE</b></p> <ul style="list-style-type: none"> <li>- FACTORY STANDARD</li> <li>- FACTORY OPTION</li> <li>- FIELD INSTALLED</li> </ul> <p><b>LOW VOLTAGE</b></p> <ul style="list-style-type: none"> <li>- FACTORY STANDARD</li> <li>- FACTORY OPTION</li> <li>- FIELD INSTALLED</li> </ul> <p><b>REPLACEMENT WIRE</b></p> <ul style="list-style-type: none"> <li>- MUST BE THE SAME SIZE AND TYPE OF INSULATION AS ORIGINAL (1050 C MIN.)</li> </ul> <p><b>WARNING</b></p> <ul style="list-style-type: none"> <li>- CABINET MUST BE PERMANENTLY GROUNDED AND CONFORM TO I.E.C., N.E.C., C.E.C. AND LOCAL CODES AS APPLICABLE.</li> </ul>	<ol style="list-style-type: none"> <li>CONNECTORS SUITABLE FOR USE WITH COPPER CONDUCTORS ONLY.</li> <li>COMPRESSOR MOTOR COMPRESSOR THERMALLY PROTECTED AND ALL 3 PHASE ARE PROTECTED UNDER PRIMARY SINGLE PHASE CONDITIONS.</li> <li>CONNECT FIELD WIRING IN GROUNDED RAIN TIGHT CONDUIT TO FUSED DISCONNECT DISCONNECT, VOLTAGE AND PHASE PER RATTLING PLATE.</li> <li>LOW VOLTAGE CIRCUIT TO BE N.E.C. CLASS 2 WITH A CLASS 2 TRANSFORMER 24 VOLT, 60HERTZ.</li> <li>TO THERMOSTAT SUB-BASE. REFER TO SYSTEM SCHEMATICS OR SCHEMATICS ON INDOOR SECTION FOR LOW VOLTAGE CONTROL WIRING.</li> </ol>	<p><b>COMPONENT CODES</b></p> <ul style="list-style-type: none"> <li>CC COMPRESSOR CONTACTOR</li> <li>CCH CRANKCASE HEATER</li> <li>COMP COMPRESSOR</li> <li>GND GROUND, CHASSIS</li> <li>HGS HOT GAS SENSOR</li> <li>HPC HIGH PRESSURE CUT-OUT CONTROL</li> <li>LAC LOW AMBIENT COOLING CONTROL</li> <li>LPC LOW PRESSURE CUT-OUT CONTROL</li> <li>OPM OUTDOOR FAN MOTOR</li> <li>OPT OPTIONAL</li> <li>RC RUN CAPACITOR</li> <li>RES RESISTOR</li> <li>SC STAR CAPACITOR</li> <li>SR STAR RELAY</li> <li>TB TERMINAL BLOCK</li> <li>TDC TIME DELAY CONTROL</li> </ul>	<p><b>WIRE COLOR CODE</b></p> <ul style="list-style-type: none"> <li>BK --- BLACK</li> <li>BR --- BROWN</li> <li>BL --- BLUE</li> <li>G --- GREEN</li> <li>GY --- GRAY</li> <li>O --- ORANGE</li> <li>PR --- PURPLE</li> <li>R --- RED</li> <li>W --- WHITE</li> <li>Y --- YELLOW</li> </ul>

# EL3T WIRING DIAGRAM (1.5TR - 3.0TR)

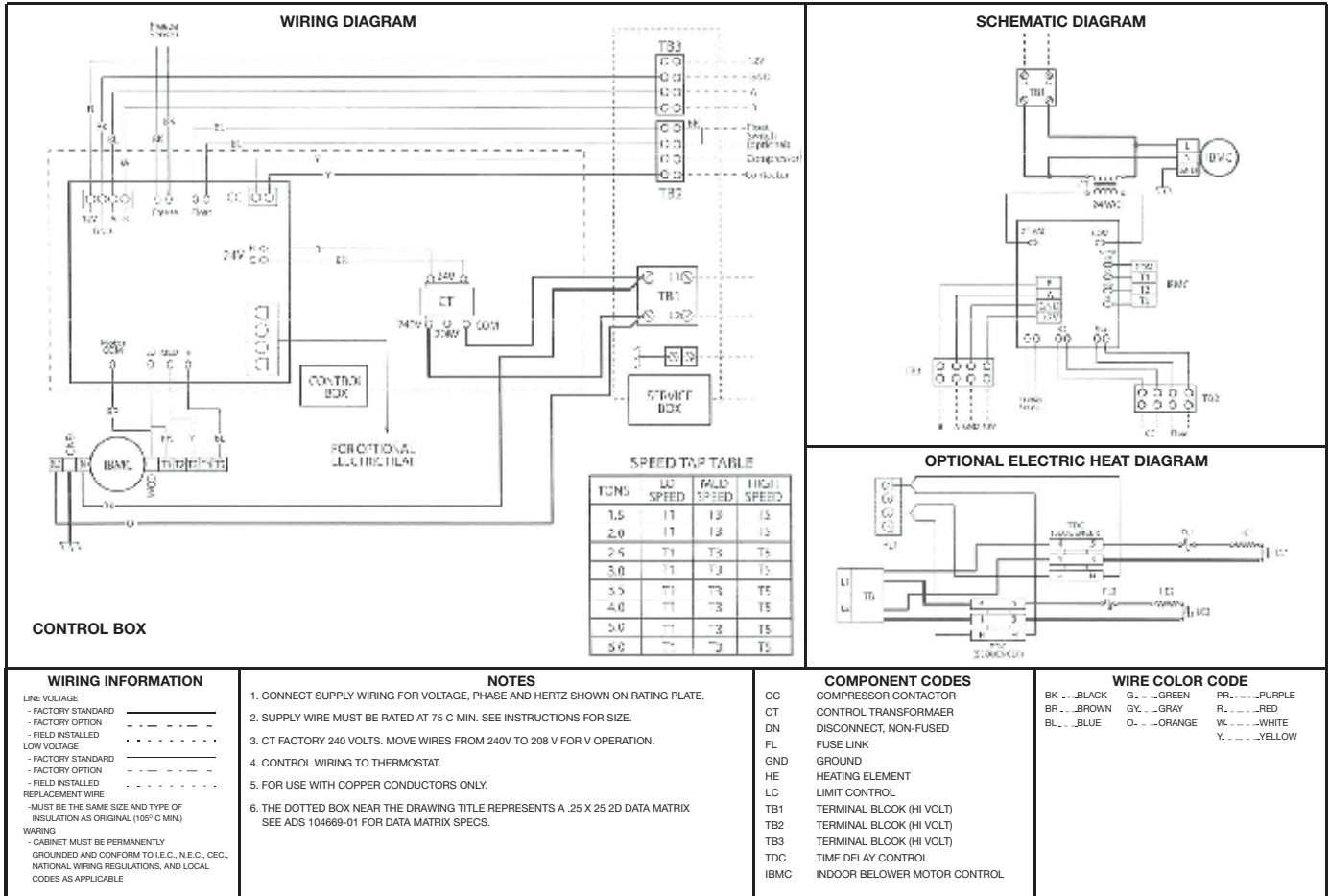

# EL3T WIRING DIAGRAM (3.5TR - 5.5TR)

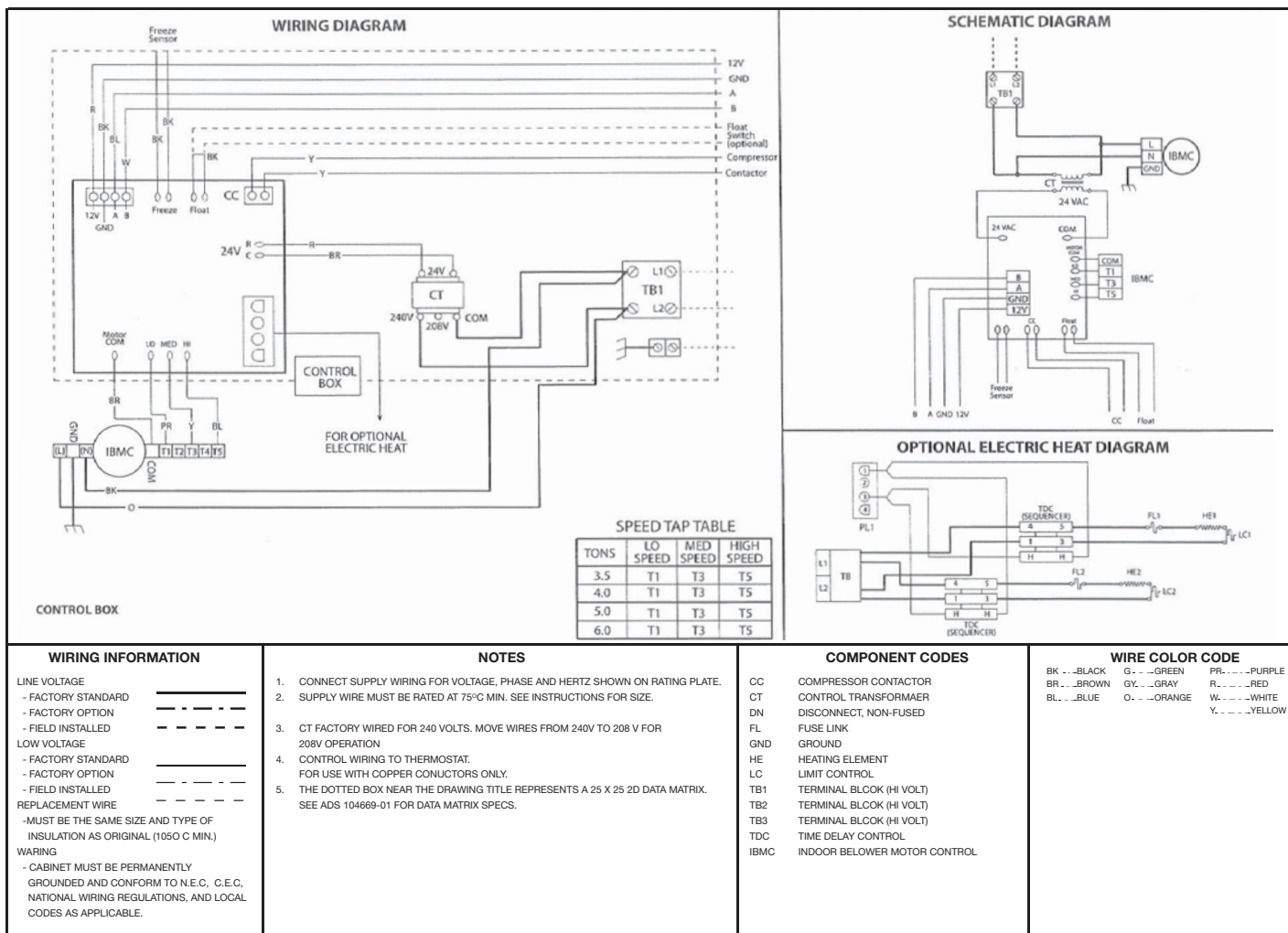



## GUIDE SPECIFICATIONS

### General

#### Condensing Unit Description

Outdoor-mounted, air-cooled, split-system air conditioner composite base pan unit suitable for ground or rooftop installation. Unit consists of a hermetic compressor, an air-cooled coil, propeller-type condenser fan, suction and legend line service valve, and a control box. Unit will discharge supply air upward as shown on contract drawings. Unit will be used in a refrigeration circuit to match up to a coil / air handler unit.

#### Quality Assurance

- Unit will be rated in accordance with the latest edition of AHRI Standard 210/240.
- Unit will be certified for capacity and efficiency.
- Unit construction will comply with latest edition of ANSI/ASHRAE and with NEC.
- Unit will be constructed in accordance with UL standards.
- Unit cabinet will be capable of withstanding ASTM B117 1008-hr salt spray test.
- Air-cooled condenser coils will be leak tested at 150 psig and pressure tested at 550 psig.
- Unit constructed in ISO9001 approved facility.

#### Delivery, Storage, and Handling

- Unit will be shipped as single package only and is stored and handled per unit manufacturer's recommendations.

#### Products Equipment

Factory assembled, single piece, air-cooled air conditioner unit. Contained within the unit enclosure is all factory wiring, piping, controls, compressor, refrigerant charge R-410A, and special features required prior to field start-up.

#### Unit Cabinet

- Unit cabinet will be constructed of galvanized steel, bonderized, and coated with a powder coat paint.
- All units constructed with louver coil protection and corner post. Louver can be removed by removing one fastener per louver panel.

#### Fans

- Condenser fan will be direct-drive propeller type, discharging air upward.
- Condenser fan motors will be totally enclosed, 1-phase type with class B insulation and permanently lubricated bearings. Shafts will be corrosion resistant.
- Fan blades will be statically and dynamically balanced.
- Condenser fan openings will be equipped with coated steel wire safety guards.

#### Compressor

- Compressor will be hermetically sealed.
- Compressor will be mounted on rubber vibration isolators.

#### Condenser Coil

- Condenser coil will be air cooled.
- Coil will be constructed of aluminum fins mechanically bonded to copper tubes.

#### Refrigeration Components

- Refrigeration circuit components will include liquid-line shutoff valve with sweat connections, vapor-line shutoff valve with sweat connections, system charge of R-410A refrigerant, and compressor oil.
- Unit will be equipped with factory provided filter drier for R-410A refrigerant for field installation.

#### Operating Characteristics

- The capacity of the unit will meet or exceed \_\_\_\_ Btuh at a suction temperature of \_\_\_\_ °F/°C. The power consumption at full load will not exceed \_\_\_\_ kW.
- Combination of the unit and the evaporator or fan coil unit will have a total net cooling capacity of \_\_\_\_ Btuh or greater at conditions of \_\_\_\_ CFM entering air temperature at the evaporator at \_\_\_\_ °F/°C wet bulb and \_\_\_\_ °F/°C dry bulb, and air entering the unit at \_\_\_\_ °F/°C.
- The system will have a SEER of \_\_\_\_ Btuh/watt or greater at DOE conditions.

#### Electrical Requirements

- Nominal unit electrical characteristics will be \_\_\_\_ v, single phase, 60 hz. The unit will be capable of satisfactory operation within voltage limits of \_\_\_\_ v to \_\_\_\_ v.
- Nominal unit electrical characteristics will be \_\_\_\_ v, three phase, 60 hz. The unit will be capable of satisfactory operation within voltage limits of \_\_\_\_ v to \_\_\_\_ v.
- Unit electrical power will be single point connection.
- Control circuit will be 24v.

#### Special Features

- Refer to section of this literature identifying accessories and descriptions for specific features and available enhancements.





# GUIDE SPECIFICATIONS

## General

### Air Handling Unit Description

Indoor installed, blow through type Blower coil unit with factory fitted air filter. Unconditioned return air is drawn through a cooling heat exchanger via synthetic media filter. The cooling heat exchanger cools and dehumidifies the air and supplies to the zone to be conditioned.

Furnish and install as shown on the drawing Rheem Model \_\_\_\_\_ blow through air handler suitable for both horizontal and vertical applications.

### Quality Assurance

- Unit will be rated in accordance with the latest edition of AHRI Standard 210/240 and or ISO 13253.
- Unit construction will comply with latest edition of ANSI/ASHRAE and NEC.
- Unit will be constructed in accordance with UL standards and according to appropriate section of IEC 60335 -1,-2-40.
- Unit cabinet will be capable of withstanding ASTM B117 1008-hr salt spray test.
- Direct Expansion Cooling coils will be leak tested at 150 psig and pressure tested at 550 psig.
- Unit constructed in ISO9001 approved facility.

### Delivery, Storage, and Handling

- Unit will be shipped as single package only and is stored and handled per unit manufacturer's recommendations.

### Equipment

Factory assembled, single piece, draw through type blower coil unit. Contained within the unit enclosure are all factory wiring, piping, controls, filters, insulation, blower, motor ,coil and special features required prior to field start-up.

### Unit Cabinet

- Unit cabinet will be constructed of galvanized steel and coated with paint. The thickness of the powder coat painted.

### Motor

Motor shall be a Constant Torque Motor (ECM) which provides enhanced EER performance with Rheem outdoor units.

### Coils

Coils shall be fabricated of 3/8" [10 mm] O.D. seamless copper tubing expanded into aluminum fins. All coils shall be submitted to an air pressure test of up to 550 PSIG [2068 kPa]. Units shall be shipped with a nitrogen holding charge. Airflow shall be blow through design providing uniform air distribution across the coil surface.

### Blower, Bearings And Shaft

Blower shall be a double width, double inlet, forward curve, centrifugal type, statically and dynamically balanced, and constructed of galvanized steel.

### Drain Pan

The drain pan shall be manufactured of plastic to protect against corrosion. The pan shall have internally threaded pipe size drain connections and shall be designed to accept condensate in either horizontal or vertical type applications. The drain pan shall be double slope design in accordance with Ashrae 62 requirement.

### Filters

Duly factory fitted filter made up of synthetic woven media. Synthetic media permanently molded in the plastic frame.

### Cabinet

Cabinets shall be manufactured of galvanized steel subjected to multi-stage cleaning and finished with Pre paint. Units shall have removable service access panels.

### Insulation

Cabinets shall be insulated with 1/2" [13 mm] by 1 1/2 pound [.68 kg] density fiberglass insulation coated with neoprene and bonded to the cabinet surface with a U.L. approved adhesive. Insulation shall have fire retarding characteristics in accordance with UL smoke developed rating not to exceed 50 and flame spread rating of 25 per Underwriters Laboratories testing procedures.

### Factory Testing

In addition to the pre-assembly testing mentioned above, each coil shall be leak tested after assembly into the unit. While under pressure, the coil shall be leak tested using an Electronic Leak Detector.

### Electric Heaters (Field Installed –if Applicable)

UL and cUL listed electric heater kits shall be available in a wide range of capacities. All kits shall offer up to two stages of capacity, blower motor controller and single point connection. Heater kits shall be available for installation directly on the supply fan discharge for either horizontal or vertical applications.



Notes

**SAGN+EL3T Series**







The new degree of comfort.®

*In keeping with its policy of continuous progress and product improvement, Rheem reserves the right to make changes without notice.*

Rheem Heating Cooling & Water Heating • P. O. Box 17010  
Fort Smith, Arkansas 72917 • [www.Rheem.com](http://www.Rheem.com)

RHEEM MANUFACTURING MEA FZE  
Dubai Airport Freezone (DAFZA), UAE



INTEGRATED AIR & WATER

FORM NO. EXS11-981 Rev. 6